



US008948411B1

(12) **United States Patent**
Moser

(10) **Patent No.:** **US 8,948,411 B1**
(45) **Date of Patent:** **Feb. 3, 2015**

(54) **ERGONOMIC TUBULAR ANECHOIC CHAMBERS FOR USE WITH A COMMUNICATION DEVICE AND RELATED METHODS**

(71) Applicant: **Scott A. Moser**, San Diego, CA (US)

(72) Inventor: **Scott A. Moser**, San Diego, CA (US)

(*) Notice: Subject to any disclaimer, the term of this patent is extended or adjusted under 35 U.S.C. 154(b) by 0 days.

(21) Appl. No.: **14/280,523**

(22) Filed: **May 16, 2014**

Related U.S. Application Data

(60) Provisional application No. 61/949,239, filed on Mar. 7, 2014, provisional application No. 61/949,234, filed on Mar. 6, 2014, provisional application No. 61/941,306, filed on Feb. 18, 2014.

(51) **Int. Cl.**
H04R 3/02 (2006.01)
G10K 11/00 (2006.01)
H04R 1/08 (2006.01)

(52) **U.S. Cl.**
CPC **G10K 11/002** (2013.01); **H04R 1/083** (2013.01)
USPC **381/73.1**; 381/71.1; 381/71.2; 381/71.7; 381/344; 381/355; 379/440; 379/441; 379/433.01; 455/90.3

(58) **Field of Classification Search**
CPC H04R 1/02; H04R 1/04; H04R 1/08; H04R 1/083; H04R 2499/11; H04R 1/1083; G10K 11/002; G10K 11/1788; G10K 11/175; G10K 2210/108; H04M 1/03
USPC 381/73.1, 71.1, 71.2, 71.7, 344, 355; 379/440, 441, 433.01; 455/90.3

See application file for complete search history.

(56) **References Cited**

U.S. PATENT DOCUMENTS

| | | | |
|---------------|---------|--------------|---------|
| 1,800,234 A * | 4/1931 | Tuttle | 181/242 |
| 2,160,229 A | 5/1939 | Rupert | |
| 2,625,615 A | 1/1952 | Webb | |
| 2,657,609 A | 11/1953 | Strobach | |
| 3,796,842 A | 3/1974 | Guille | |
| 4,396,089 A | 8/1983 | Scully | |
| 4,792,013 A | 12/1988 | Boynton | |
| 4,890,688 A | 1/1990 | Baker | |
| 4,932,495 A | 6/1990 | Chapman | |
| 4,998,959 A | 3/1991 | Purdie | |

(Continued)

FOREIGN PATENT DOCUMENTS

| | | |
|----|-----------|--------|
| CN | 2262732 Y | 9/1997 |
| CN | 1949363 A | 4/2007 |

(Continued)

Primary Examiner — Paul Kim

(74) *Attorney, Agent, or Firm* — John K. Buche; Buche & Associates, P.C.

(57) **ABSTRACT**

Disclosed, in general, are devices that provide an air-tight chamber over a sound source while absorbing all fields of sounds from the sound source. In general, the devices feature: an anechoic chamber that is configured to receive a sound source in an air-tight manner; and an anechoic channel that is in fluid communication with the ambient atmosphere. Suitably, the anechoic chamber is adapted to capture air containing sound energy generated by the sound source, and distribute the air about an internal surface area on the inside of the chamber, wherein the internal surface area is sufficiently large to dampen or otherwise absorb the sounds energy. Preferably, the air is directed from the anechoic chamber through an anechoic channel extending therefrom to the ambient to further dampen or absorb the sound energy. In one configuration, the outer wall of the apparatus is configured to reflect ambient sounds.

20 Claims, 13 Drawing Sheets

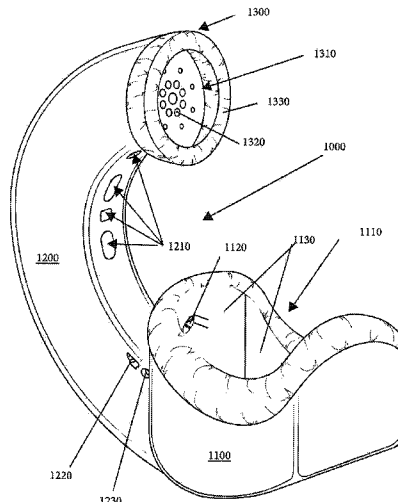

(56)

References Cited

U.S. PATENT DOCUMENTS

5,778,062 A 7/1998 Vanmoor
6,401,860 B1 6/2002 Ellington et al.
6,510,311 B1 1/2003 Stütt
7,197,140 B2 3/2007 Asaro
7,515,708 B1 * 4/2009 Doty et al. 379/440
7,532,719 B2 5/2009 Snodgrass
7,564,968 B2 7/2009 Ayers et al.
7,783,034 B2 * 8/2010 Manne 379/441
8,243,944 B2 * 8/2012 Almagro 381/73.1
8,532,987 B2 9/2013 Holzrichter
2002/0077838 A1 6/2002 Dutta

2007/0127659 A1 6/2007 McClory et al.
2011/0136535 A1 6/2011 DiPasquale et al.
2012/0029912 A1 2/2012 Almagro
2013/0276615 A1 10/2013 Antaki

FOREIGN PATENT DOCUMENTS

DE 19722045 7/1998
EP 0637188 A1 2/1995
EP 0831453 A3 3/1997
EP 2674048 12/2013
WO WO9914733 3/1999

* cited by examiner

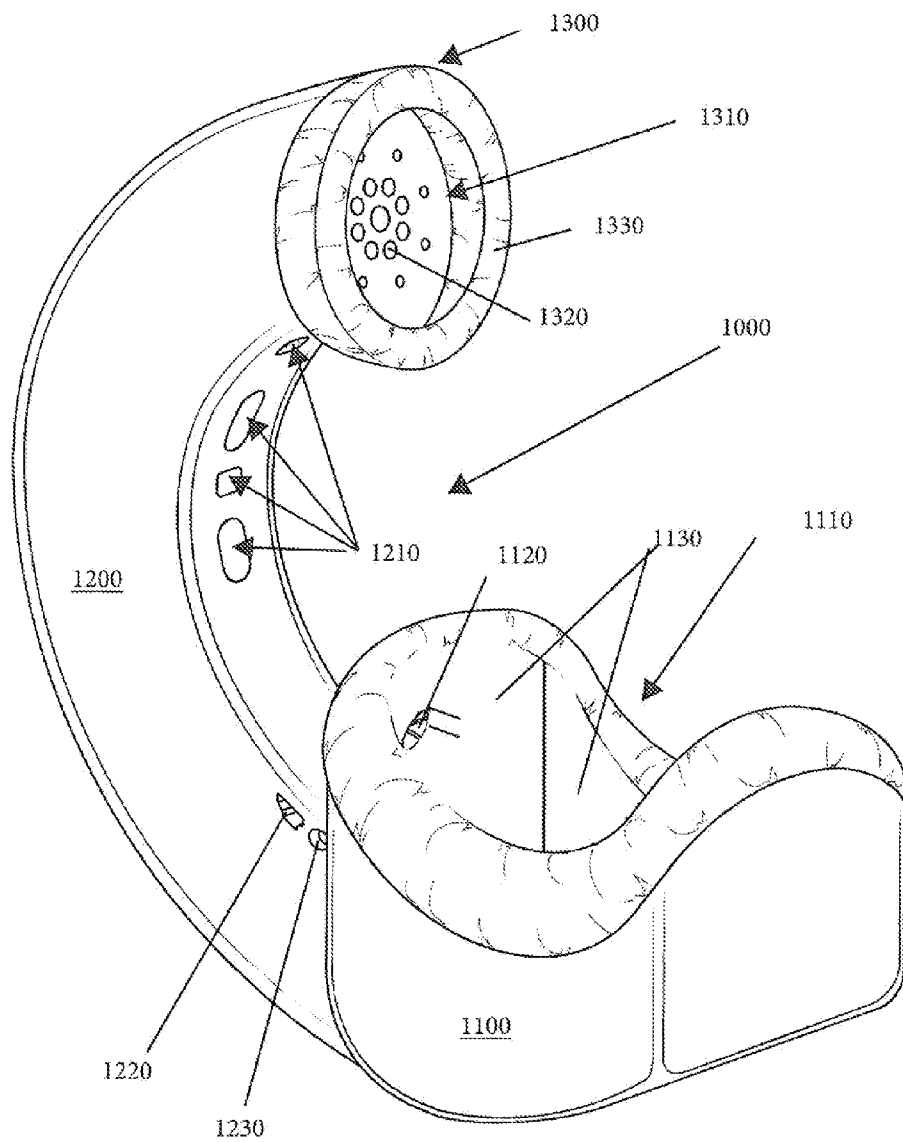

FIG. 1

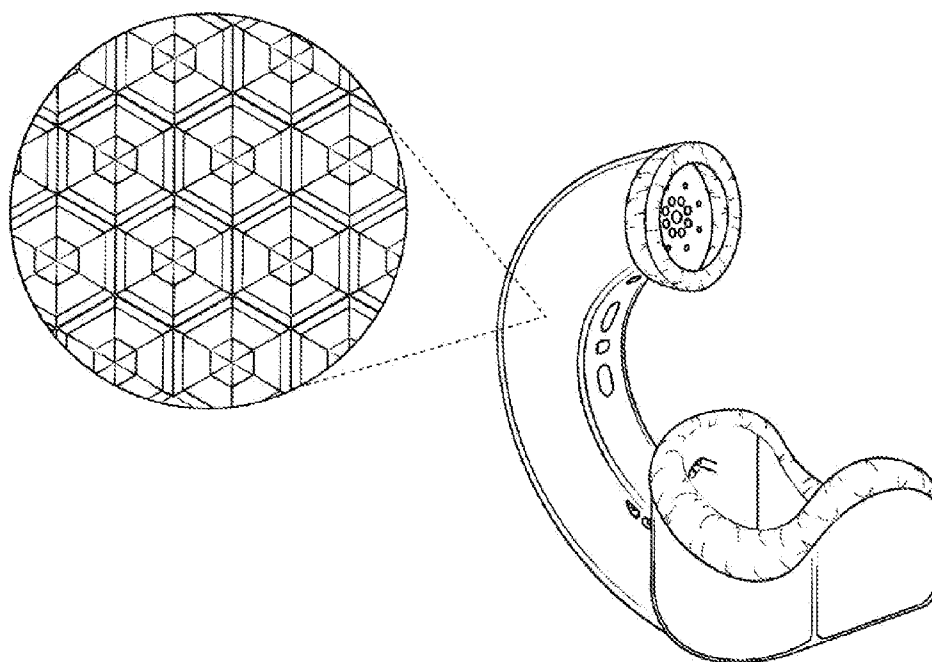

FIG. 2

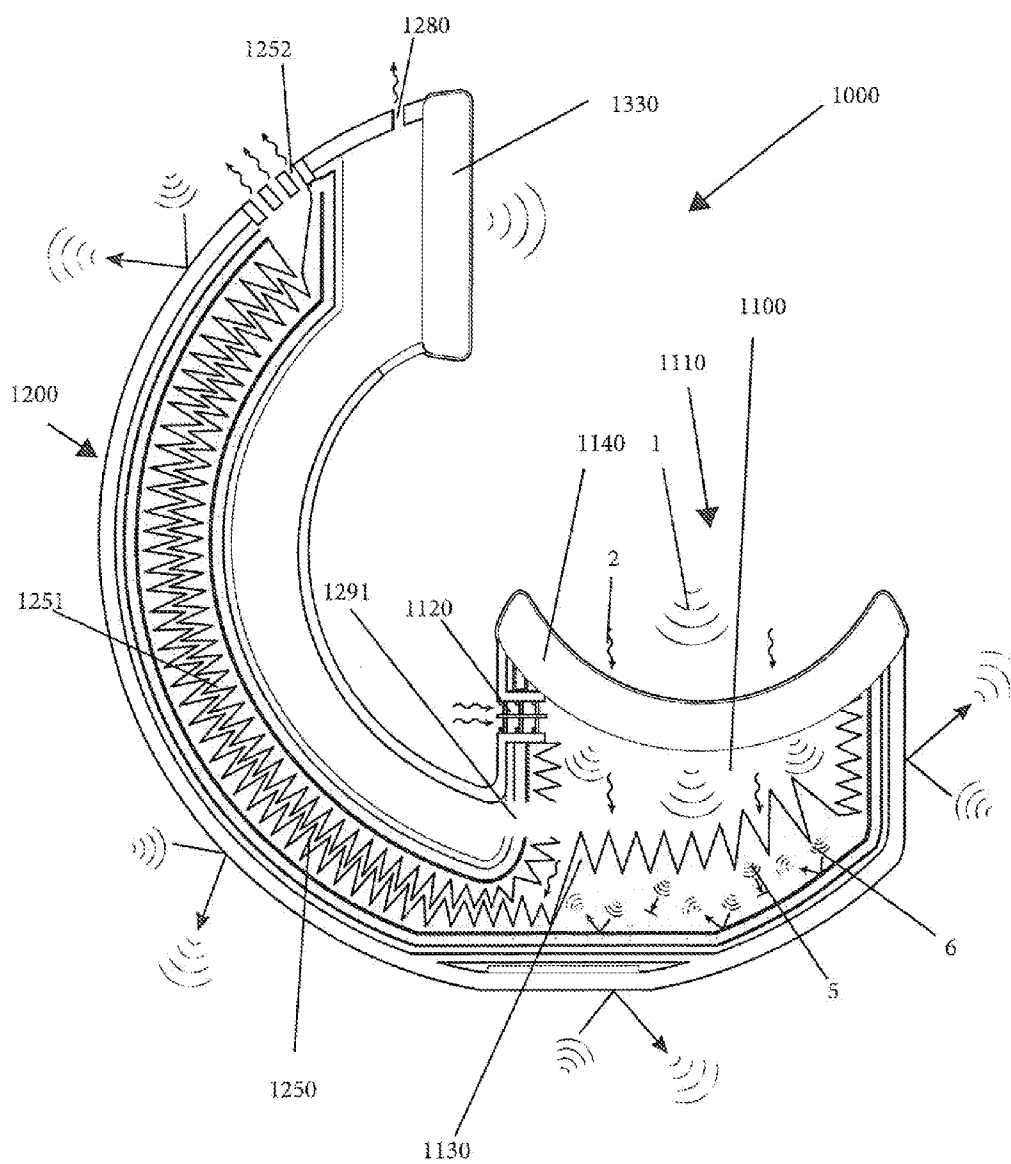

FIG. 3

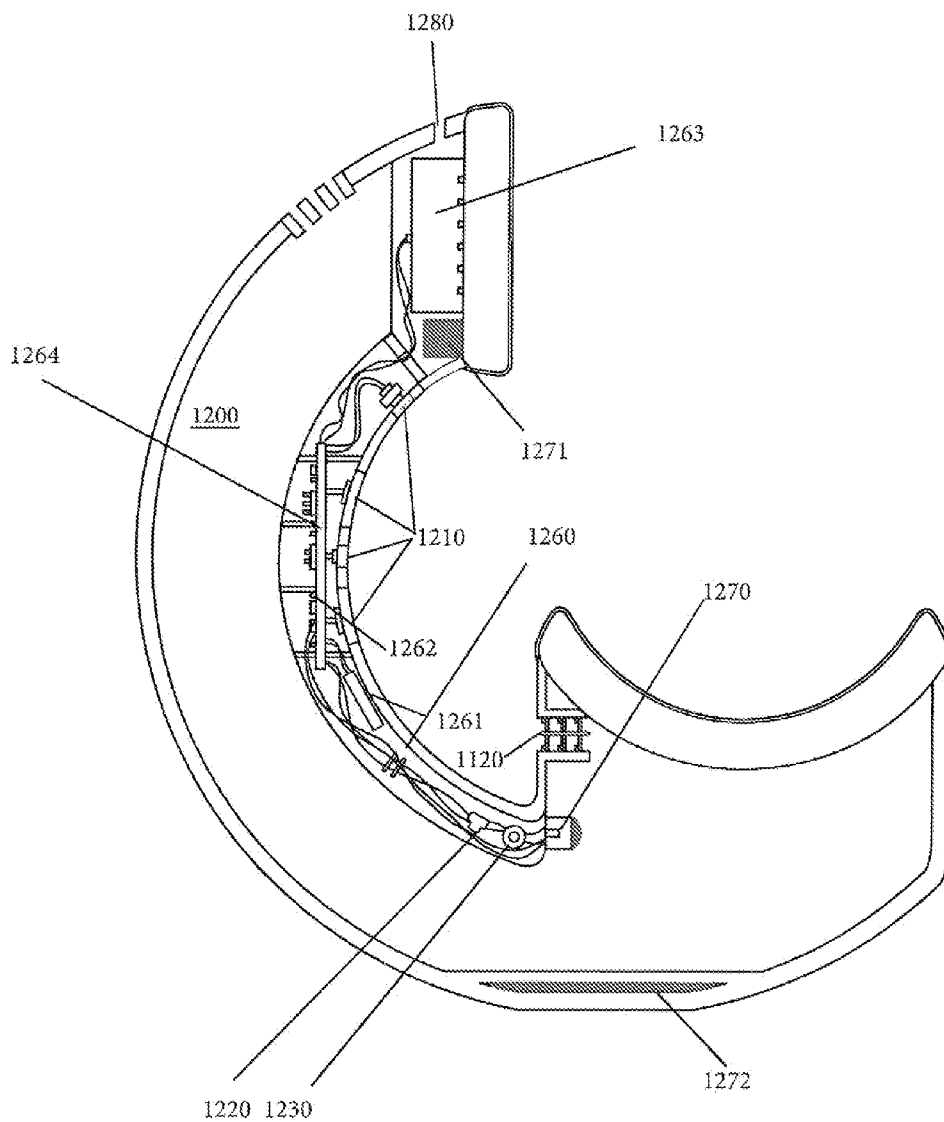

FIG. 4

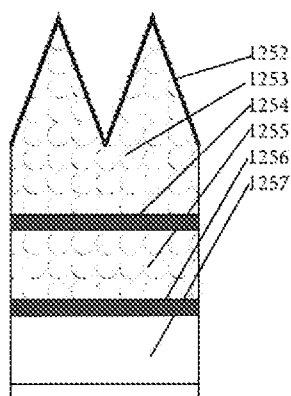

FIG. 5

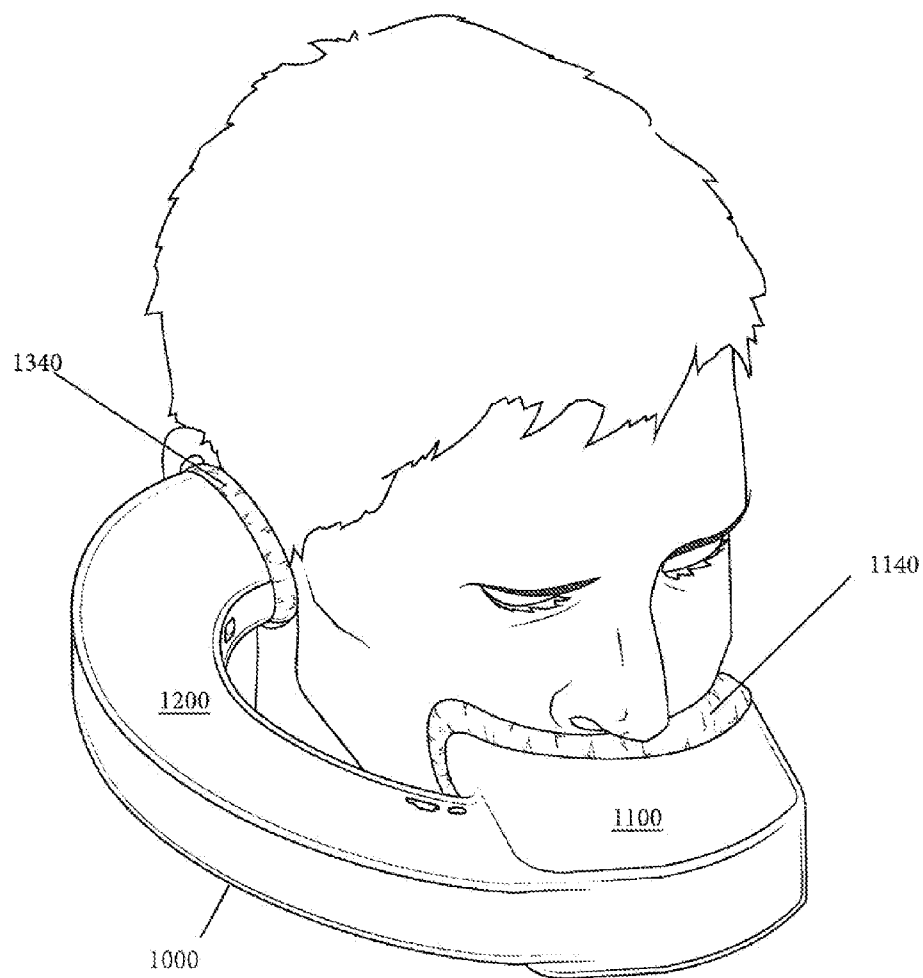

FIG. 6

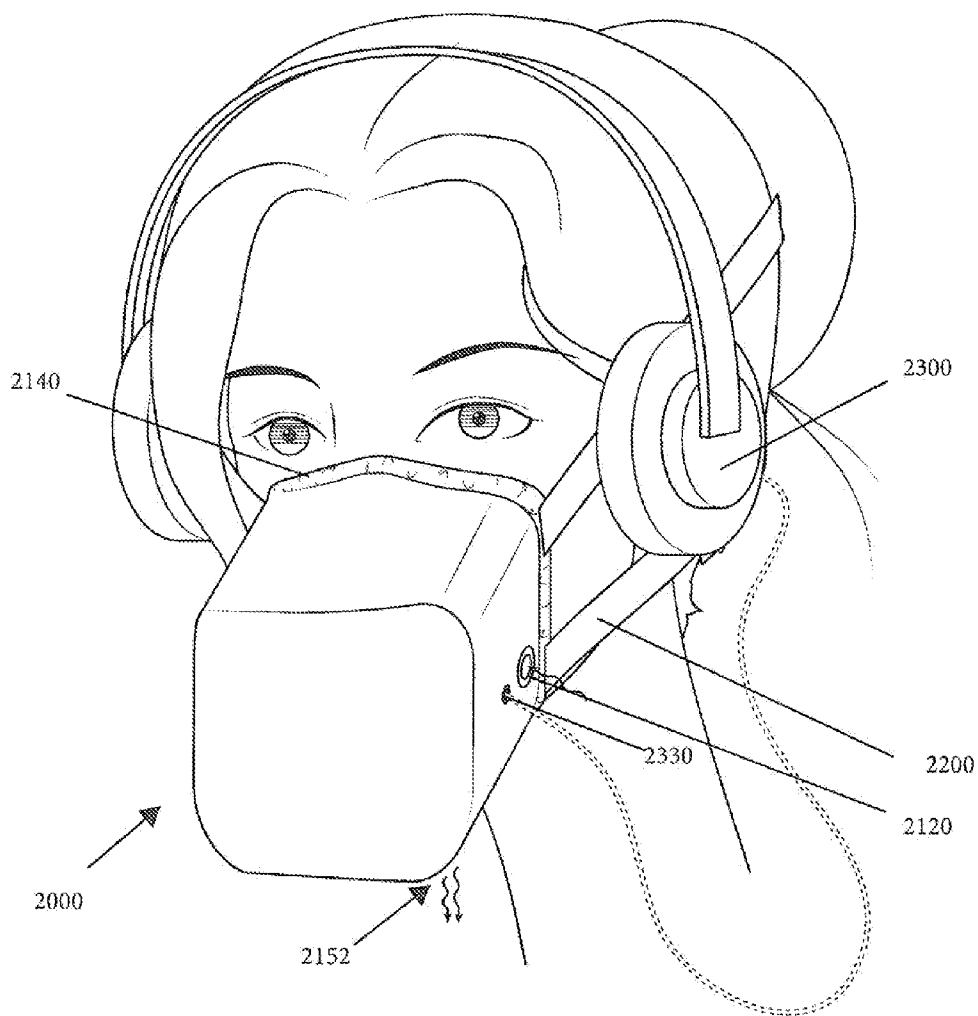

FIG. 7

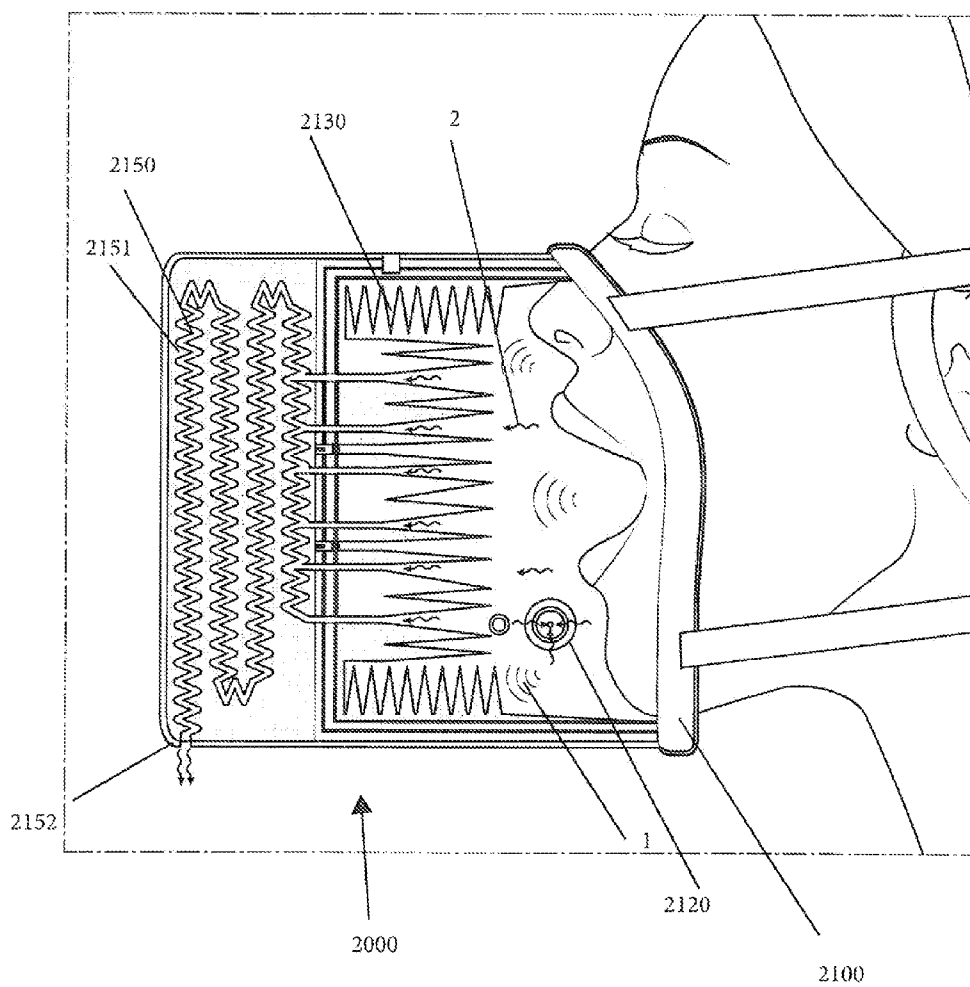

FIG. 8

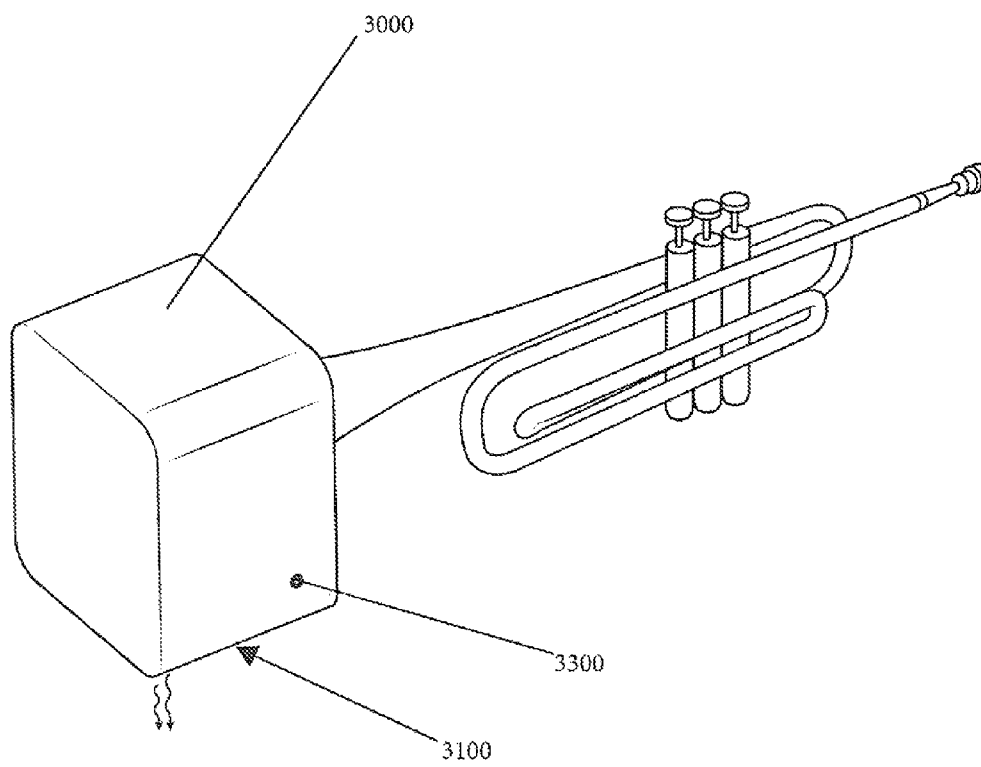

FIG. 9

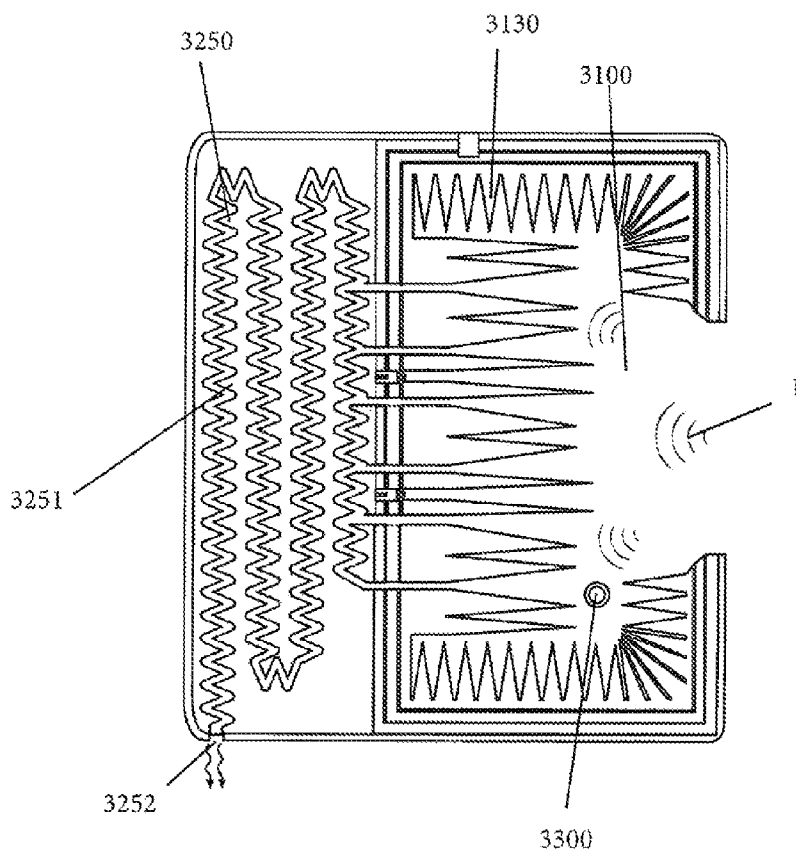

FIG. 10

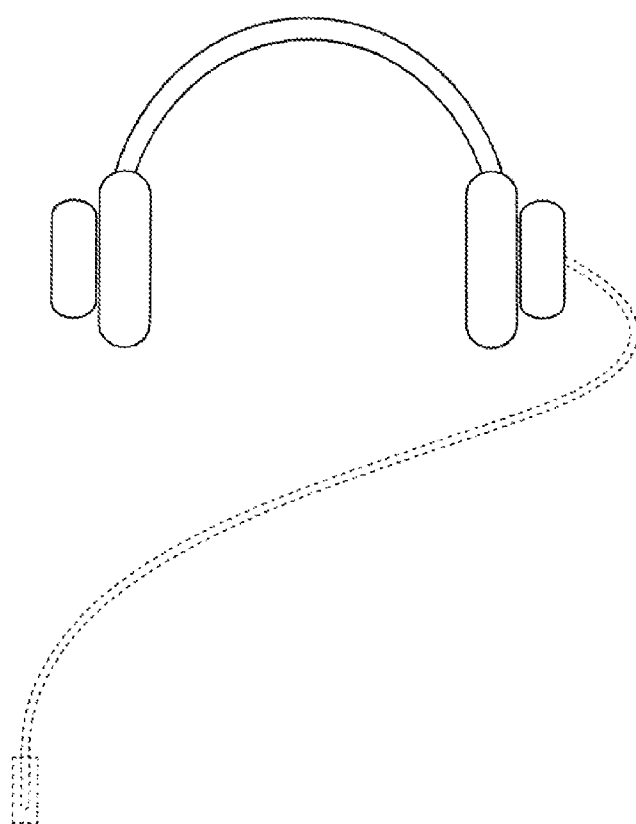

FIG. 11

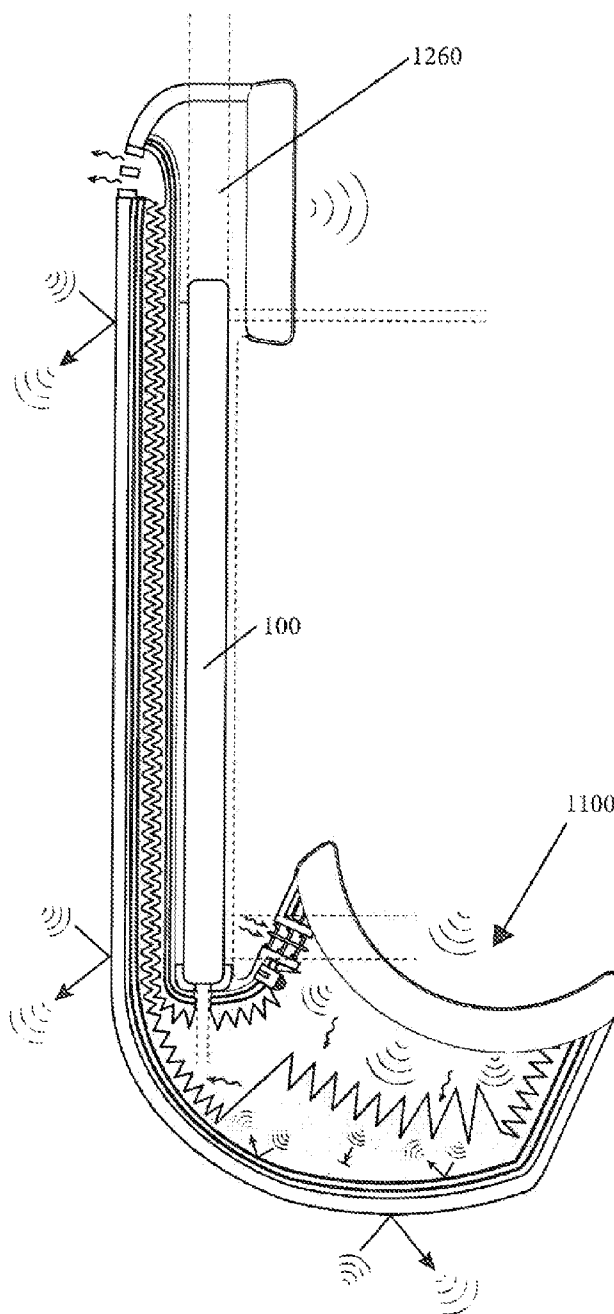

FIG. 12

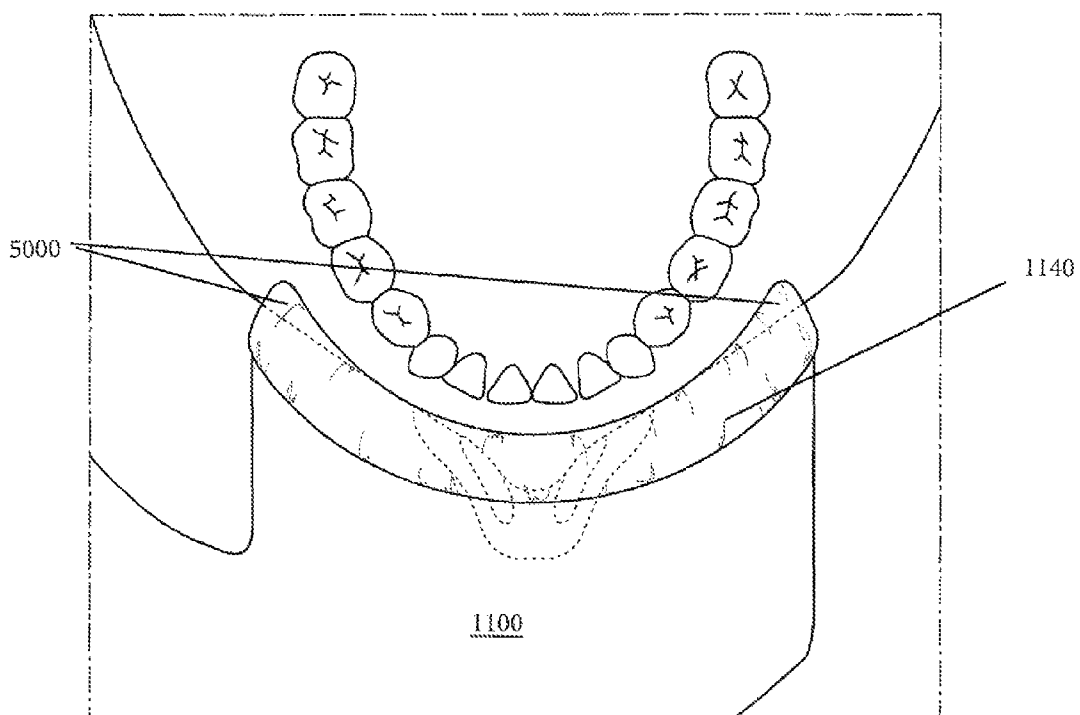

FIG. 13

1

**ERGONOMIC TUBULAR ANECHOIC
CHAMBERS FOR USE WITH A
COMMUNICATION DEVICE AND RELATED
METHODS**

CROSS-REFERENCE TO RELATED
APPLICATIONS

This application claims the benefit and priority of U.S. Prov. Pat. App. Ser. No. 61/949,239 (filed Mar. 7, 2014) 10 entitled "Accessory having an anechoic chamber for isolating noise of a wind instrument." This application also claims the benefit and priority of U.S. Pat. App. Ser. Nos. 61/949,234 (filed Mar. 6, 2014) and 61/941,306 (filed Feb. 18, 2014) 15 entitled "Tubular Anechoic Chamber for use with a communication device." These documents are incorporated by reference in their entirety.

STATEMENT REGARDING FEDERALLY
SPONSORED RESEARCH OR DEVELOPMENT

Not applicable.

BACKGROUND OF THE INVENTION

Field of Invention

The subject matter of this written description is in the field of devices for containment, absorption and directing noise from a sound source while deflecting, absorbing and reflecting ambient noise. The subject matter of this disclosure is also in the field of systems and methods for maintaining privacy or avoiding public disruption during use of a communication device such as a telephone, mobile phone, two-way radio, and the like. Finally, this invention relates to an accessory for isolating, directing, containment, and absorption of musical noise (e.g., sounds produced by singing or by musical instrument) and more particularly, to sound accessories configured to removably attach to the mouth or bell portion of a wind instrument for reducing noise expelled therefrom, for example, during a practice session.

BACKGROUND OF THE INVENTION

Mobile and fixed line communication devices ("communication devices"), such as cellular phones, two-way radios, or home phones, have become ubiquitous. In fact some reports show telephone use by eighty seven percent of the global population. The commonality of these devices has resulted in their public use within the local vicinity of others. Conventional communication devices are not always suitable for public use. First, use of a conventional communication device in public often requires the user to expose the private details of a communication to others within the local vicinity. Even when a user retreats to a secluded location, the communications are subject to eavesdropping (e.g., by parabolic microphone, binoculars for lip reading, laser sound pick-up devices, and other distance eavesdropping devices). Subjecting the details of a secret or private communication to others is particularly concerning when such details involve matters of national security (e.g., details concerning FBI, CIA, diplomat's, fire station, police, or military matters). Second, ambient noises in public areas can frequently disrupt a communication. For instance, ambient noise can frequently make it difficult for the user of the communication device to receive clear communications on the communication devices or to speak understandable commands to a device's computer

2

assistant employing voice recognizing software (e.g., SIRI® as utilized by the iPhone®). Thus, a need exists for apparatus and related methods for maintaining the privacy and clarity of communications over communication devices while avoiding the disturbance of others in the vicinity.

In view of the foregoing, many have proposed apparatus for enhancing privacy and clarity of communication devices while avoiding the disturbance of others nearby. These proposed apparatus involve covering the mouth or ear of a communication device so that a chamber is created over the mouth or ear in an attempt to confine the communicative sounds while blocking ambient noise. For instance, U.S. Pat. No. 7,564,968, US. Pub. App. No. 2011/0136535, U.S. Pat. No. 7,197,140, U.S. Pat. No. 8,778,062, and U.S. Pat. No. 7,515,708 disclose apparatus that are positioned over or in front of a mouth. Although capable of limited muffling of communicative sounds produced by the user of a communication device, these devices are not capable of capturing all of the communicative sounds of a device user that would otherwise be intelligible to those in the nearby vicinity. While some of these devices are capable of blocking small amounts of the direct field of communicative sounds, they are frequently inadequate for containing the more intense reverberant fields of the human speech sounds, for example, the reverberant fields of a male voice can be as low as eighty Megahertz (MHz). This functional inadequacy is the result of two factors. First, the materials (or lack thereof) employed are not capable of absorbing enough of the communicative sound to render the communication unintelligible to eavesdroppers. Second, the chambers are not air-tight (particularly at any interface between the apparatus and the user's face (specifically, the ear and mouth)). When a chamber and related parts of the device are not air-tight, the direct or reverberant fields of the near-field (sounds in close proximity to the sound source) communicative sound (which is an acoustic sound wave through air) can leak out from the chamber before being totally absorbed by the chamber walls. Even when such apparatus initially form a seal around the mouth of a user, these seals can be upset by either (1) the sound air pressure or acoustic particle velocity of the communicative sound's near field sound energy (which are much more extreme than direct or reverberant fields) or (2) misalignment of the mouth and chamber near the upper and lower lips (i.e., the menton-subnasale length, bitragoin-subnasale arc area, and bitragoin-menton arc area) during movements of a user's face during normal speech. Misalignment along the menton-subnasale length, bitragoin-subnasale arc area, and bitragoin-menton arc area is particularly problematic when an apparatus must simultaneously provide mouth and ear coverings use because these devices allow the ear coverings to operate despite misalignment along the and the menton-subnasale length area, bitragoin-subnasale arc area, or bitragoin-menton arc during movements of a user's face whereby a user may not even realize that sound from a private communication is being released. Even the slightest release of sound can be concerning during extremely sensitive communications over a communication device, for instance, during doctor-patient communications, lawyer-client communications, stockbroker-investor communications, interfamily communications, or communications involving national security. Furthermore, these devices are not substantially available for blocking ambient noise and thus clarity of communication using these devices can be compromised.

Other apparatus for enhancing privacy or clarity of communication involve a user facemask for creating a chamber over the mouth of a user. See, e.g., US Pub. Pat. No. 2007/0127659, U.S. Pat. No. 8,234,944, U.S. Pat. No. 7,783,034,

3

and CN Pat. No. 2262732. However, these types of apparatus suffer from the drawbacks mentioned above, with the additional problem of being attention calling. Frequently, participants of a private communication, like national security agency members, do not want additional attention drawn to them by their communication device during sensitive telephone communications. Additionally: none of these face-mask apparatus allow the user to breath freely while being used without taking the device away from their face; none of the prior art have a controlled direction of airflow with sound energy to exit out the device in a controlled manner, with the users air from speech passing across a microphone without the intake air passing by the microphone so no acoustic interference will occur with the microphone; and none of the prior art use materials that are technically capable to absorb the low base frequencies i.e. modelling clay that does not dry out and remains malleable.

Musicians, like communication device users, are frequently desirous of privately or discretely producing sounds in public areas. For instance, opera singers or woodwind instrument players may desire to practice their craft in a public park without disturbing the splendor of the general public. Like users of communication devices, a musician cannot always retreat to a secluded location or even their homes because, for example, within many neighborhoods (especially modern apartments, condominium and townhomes) people are increasingly living in closer proximity to one another. Thus a need exists for apparatus and related methods for maintaining the privacy of musical sounds.

For singers, apparatus exist that are similar to those described above in connection with communication devices. See, e.g., U.S. Pat. No. 2,625,615, U.S. Pat. No. 4,396,089, and U.S. Pat. No. 4,932,495. These devices are essentially facemasks that cover the mouth of the singer in an attempt to create a sound muffling chamber over the mouth. These apparatus are particularly susceptible to leaked sounds. As discussed above in connection with apparatus for communication privacy apparatus, such chambers either are either (a) not capable of absorbing the near, direct, and reverberant fields of a singer's voice or (b) allow sounds to leak via misalignment of the mouth and chamber along the mentocervical angle length, menton-subnasale length, bitragoin-subnasale arc, or bitragoin-menton arc during movements of a user's face. Misalignment of the face contours and mask are particularly problematic during singing since the users facial movements are exaggerated when compared to a person that is talking, particularly along the menton-subnasale length. Other problems arise in that the apparatus distort the sounds made by the user so that a user cannot totally tell if the sounds produced are correct. Therefore, a need exists for apparatus and related methods for maintaining the privacy of musical sounds of singers.

For woodwind instrument players, apparatus also exists for dampening the sound of the instrument. However, these apparatus typically involve either placing a covering around the whole instrument, or muffling the sound. These types of apparatus do not adequately address the need for apparatus that maintain the privacy of musical sounds. One reason these are inadequate is that many woodwind instruments require a user's hands to move over and about the instrument. Encasing the instrument is problematic because the encasing apparatus must feature holes that leak sound while providing hand-access or else restrict access to the instrument. Muting the instrument is problematic because the musician must hear the noises to determine whether the instrument is being played

4

correctly. As a result, a need still exists for apparatus and related methods for maintaining the privacy of musical sounds of singers.

SUMMARY OF THE INVENTION

In view of the foregoing, it is an object of this disclosure to describe apparatus for maintaining the privacy and clarity of communications over devices and sounds of musical instruments or voices. It is another objective to disclose such apparatus without the drawbacks identified above. Disclosed, in general, are devices that provide a substantially air-tight chamber over a sound source while absorbing relatively all frequency fields of speech, singing, or instrument sounds from the sound source. In general, the devices feature: anechoic chambers that are configured to receive a sound source in an air-tight manner; and anechoic channels that are in fluid communication with the ambient environment. Preferably, the anechoic channels allows air flow out of the anechoic chambers. Suitably, the anechoic chambers are adapted to capture air containing sound energy generated by the sound source, and distribute the air about internal anechoic acoustical surface areas on the inside of the chambers, wherein the internal surface areas are maximized and sufficiently large to dampen or otherwise absorb the sound energy. The users face inside the sealed area also acts to absorb sound waves in the anechoic chamber. Preferably, the air is directed from the near-field anechoic sound chamber through a tubular anechoic channel extending therefrom to the ambient atmosphere to further dampen or absorb and contain the sound energy. Once sound energy is absorbed from the twin specific anechoic chambers, the air preferably exhausts from the apparatus substantially free of any sound energy. This feature permits a user to pass fresh air into the chamber via an air intake mechanism without pressure buildup as the user's sound containing air is vented out of the anechoic channel. In one configuration, the outer wall of the apparatus is configured to reflect ambient sounds. In another embodiment, the apparatus features an ear sealed chamber to keep ambient sounds out of a user's ear.

It is yet a further objective to disclose devices that provide an air-tight chamber over the mouth and ear of a user while absorbing all megahertz frequency fields of communicative sounds by male and female speakers. In one embodiment, the device is defined by: an anechoic chamber with a mouth opening plus an anechoic channel for dampening acoustics about a receiver portion of a communication device; and an ear chamber with an ear opening dampening acoustics about a microphone of a communication device. In a preferred embodiment, the ear and anechoic chambers are configured for placement so that the device lies along the mentocervical angle, mentocervical angle length, menton-subnasale length, bitragoin-subnasale arc, or bitragoin-menton arc of a user at a range of nineteen to twenty three degrees. Other embodiments may not incorporate these angles. In use, a mouth may be placed in the mouth opening to create a substantially air-tight seal and position the mouth so that the acoustics of a communicative sound from the mouth are directed toward the receiver portion of the communication device within the anechoic chamber. By allowing the specific ergonomic design of the mouth seal to push easily into the soft tissue of a user's face around the user's teeth, a substantially air-tight seal is created that does not hinder the user's ideal pronunciation and intonation of verbs adjectives, pronouns and other words easily without stress on the areas of the lips used for pronunciation. In a preferred embodiment, air from the user's breath during speech is directed through the anechoic channel

5

for improved acoustic absorption and microphone sound pick-up. The result is voice communication being contained within the anechoic chamber of the device for maintaining privacy of the phone conversation.

Preferably, the apparatus is configured to fit securely over the ear and mouth of a user, without breaking the air tight seal between the mouth opening and mouth of a user and the seal between the ear opening and the ear of a user. Suitably, this is accomplished via positioning the apparatus at a metocervical angle in a range of fifteen and twenty five degrees relative to the face of a user. Other embodiments need not incorporate these angles. A preferable metocervical angle position for the apparatus is about nineteen degrees for female users and about twenty three degrees for male users. These metocervical angle positions result in the appropriate ear to mouth engagement at an eighty-eighth percentile relationship for both of the bitragion sub-nasale arc and the bitragion-menton arc anthropometric measurements. This insures even/equal user pressure around the entire menton subnasale area (i.e., direct contact area of the entire perimeter of the product's face sound seal) and the center of the ear.

It is yet a further objective to provide an apparatus and related methods for maintaining the privacy of musical sounds. In one embodiment, the apparatus is defined by an anechoic chamber with an anechoic channel. In use, the apparatus may be generally used during a learning or practice session. In one embodiment, the anechoic chamber is defined by a receptacle body adapted to engage at its opening with a bell portion of a woodwind instrument so that the terminal end of the instrument is substantially within the chamber. In one embodiment, the anechoic chamber is defined by a receptacle body adapted to engage at its opening with the mouth of a singer so that mouth of the user is substantially directed to within the chamber. In either embodiment, the chamber is adapted to capture air expelled from a sound source, and distribute the air about an internal surface area therein, wherein the internal surface area is sufficiently large to minimize vibrations and echoing. Preferably, the air is directed from the anechoic chamber through an anechoic channel extending therefrom. The anechoic channel comprises a series of loops for further absorbing and reducing vibrations and noise. The anechoic chamber comprises a terminal port wherein the air is released into the surrounding environment with significantly reduced noise. Furthermore, the apparatus may further comprise at least one microphone and an electronic means for communicating sound from within the anechoic chamber to outside of the chamber, such as to headphones or an external speaker.

Other objectives and desires may become apparent to one of skill in the art after reading the below disclosure and viewing the associated figures. Also, these and other embodiments will become apparent from the drawings.

BRIEF DESCRIPTION OF THE FIGURES

The manner in which these objectives and other desirable characteristics can be obtained is explained in the following description and attached figures in which:

FIG. 1 is a perspective of the device;

FIG. 2 is a perspective view of the device of FIG. 1 with a blow-out depicting the sound reflecting surface contours of the device;

FIG. 3 is a cross section of an apparatus for ensuring the privacy and clarity of communications over communication devices;

6

FIG. 4 is a cross section of the shell of the device showing isolated anechoic chambers separate from the electric components;

FIG. 5 is a cross section of a side wall of an anechoic chamber;

FIG. 6 is an environmental view of the device;

FIG. 7 is a perspective and environmental view of the device;

FIG. 8 is a cross section and environmental view of a device for maintaining the privacy of a singer's voice;

FIG. 9 is a perspective and environmental view of the apparatus;

FIG. 10 is a cross section of an apparatus for ensuring the privacy of sounds generated via a woodwind instrument;

FIG. 11 is a view of headphones for use with the device of FIGS. 7 and 9;

FIG. 12 is a cross-section of an alternate embodiment of the device of FIG. 1;

FIG. 13 is an environmental view of the apparatus of FIG. 1, in use.

It is to be noted, however, that the appended figures illustrate only typical embodiments of the disclosed assemblies, and therefore, are not to be considered limiting of their scope, for the disclosed assemblies may admit to other equally effective embodiments that will be appreciated by those reasonably skilled in the relevant arts. Also, figures are not necessarily made to scale.

DETAILED DESCRIPTION OF PREFERRED EMBODIMENTS

Disclosed, in general, are devices that provide an air-tight chamber over a sound source while trapping, containment, absorption, directing and deflecting all fields of sounds from the sound source (e.g., the mouth of a human or a woodwind instrument). In general, the devices feature: a specialized anechoic chamber that is configured to receive a sound source in an air-tight manner; and a specialized anechoic channel that is in fluid communication with the ambient atmosphere. Suitably, the anechoic chamber is adapted to capture air containing sound energy generated by the sound source, and distribute the air about an internal surface area on the inside of the chamber, wherein the internal surface area is sufficiently large to dampen or otherwise absorb the sounds energy. Preferably, the air is directed from the anechoic chamber through an anechoic tubular channel extending therefrom to the ambient to further dampen or absorb the sound energy. In one configuration, the outer wall of the apparatus is configured to reflect ambient sounds. The more specific details of the preferred embodiment are disclosed in connection with the figures.

By allowing the specific ergonomic design of the mouth seal to push easily into the soft tissue of a user's face around the user's teeth, a substantially air-tight seal is created that does not hinder the user's ideal pronunciation and intonation of verbs adjectives, pronouns and other words easily without stress on the areas of the lips used for pronunciation. Preferably, the apparatus is configured to fit securely over the ear and mouth of a user, without breaking the air tight seal between the mouth opening and mouth of a user and the seal between the ear opening 1310 and the ear of a user. Suitably, this is accomplished via positioning the apparatus at a metocervical angle in a range of fifteen and twenty five degrees relative to the face of a user. A preferable metocervical angle position for the apparatus is about nineteen degrees for female users and about twenty three degrees for male users. These metocervical angle positions result in the appropriate ear to

mouth engagement at an eighty-eighth percentile relationship for both of the bitrignon sub-nasale arc and the bitrignon-menton arc measurements. This insures even/equal user pressure around the entire menton subnasale area (i.e., direct contact area of the entire perimeter of the product's face sound seal) and the center of the ear.

FIG. 1 is a perspective view of an apparatus 1000 for maintaining the privacy and clarity of communications made over a communication device. As shown, the apparatus 1000 is generally in the shape of a telephone handset and defined by: (1) an anechoic chamber 1100 with a mouth opening 1110 for engaging a mouth of a user; (2) a handle 1200; and, (3) an ear chamber 1300 with an ear opening 1310 for engaging the ear of a user.

As shown in FIG. 1, the handle 1200 is generally curved wherein: an anechoic chamber 1100 is generally positioned at the lower end of the handle 1200; and the ear chamber 1300 is positioned at an upper end of the handle. Both the anechoic chamber 1100 and the ear chamber 1300 generally define basins at either end of the handle 1000. The specifically designed anechoic chamber 1100 preferably features contours 1130 on its inner walls and cushioning 1140 around the lip of the mouth opening. Similarly, the ear chamber features cushioning 1330 around the lip of the ear opening 1310. Finally, the handle 1200 is configured with a curve so that it can be gripped by the hand of a user while the ear and anechoic chambers are simultaneously positioned over the ear and mouth. In a preferred embodiment, the handle has a curvature and shape of a banana fruit for the ergonomic use and comfort of a user. Although not shown, the handle 1200 may further feature grips to assist users with arthritis afflictions in holding the apparatus 1000.

As discussed in greater detail below, the apparatus 1000 is designed to receive and transmit telephone communications from and to a communication device (e.g., wirelessly via Bluetooth® type technology) or wired communication device (e.g., landline phone) and generally be operated in the manner of a telephone handset. For this reason, FIG. 1 depicts an air inlet 1120 within the anechoic chamber 1100. As discussed in greater detail below, the vent 1120 suitably features a triple layer air seal design that blocks ambient sounds from entering the anechoic chambers during a user's speech and that easily flexes under a negative pressure within the chamber 1100 to allow sufficient air into the chamber 1100 during speech. In other words, the vent 1120 makes it so the user does not have to pull away from the apparatus 1000 to breathe during use. Also depicted are (a) phone controls 1210 (e.g., volume and accept or decline buttons, hold button, or mute speaker button) on the handle 1200, power ports 1220 on the handle 1200, an audio port 1230 (e.g., for receiving a headphone jack), and speaker holes 1320 within the ear chamber 1300. In a preferred embodiment, the phone controls 1210 include a hold or mute button that will allow the user essentially turn off the phone when not engaged against the user's face to shield the listening party from the ambient noise or discussion of the user.

FIG. 2 is a recreation of the perspective view of the apparatus 1000 FIG. 1, with an additional blow-out view to illustrate the external surface of the apparatus 1000. As shown in the blow-out view, the external surface of the apparatus is defined by a hex-skin or a plurality of hexagonal tiles positioned in an array over the surface of the apparatus 1000. In a preferred embodiment, each hexagon defines a plane or face for reflecting ambient sound energy, wherein each plane or face is angled on a lightly different angle relative to the plane of any adjacent hexagon within the skin. This angular offset from polygonal shapes results in ambient sound deflection to

maintain the quality of sounds within the apparatus. Suitably, this angular offset weakens the ambient sound's intensity by not allowing sound energy to focus on a specific area on the surface of the outside of the anechoic chamber. In a preferred embodiment, the surface of each hexagon is contoured to further disrupt ambient sounds via minimal absorption and deflection so that large focused sound energy cannot enter the anechoic chamber. Other polygonal patterns may be integrated.

FIGS. 3 and 4 are cross-sections of the apparatus 1000 depicted in FIG. 1. These cross-sections are intended to illustrate the interior workings of the claimed device. Specifically, FIG. 3 illustrates the inner workings of the sound trapping, containment, absorption, directing and deflecting components of the apparatus 1000 and FIG. 4 illustrates the electrical components for telephonic communications. Referring to both FIGS. 3 and 4, the phone electronics are, (apart from a microphone 1270) disposed within the acoustic chamber, and preferably isolated from sound absorbing components to ensure the sound components create a substantially or completely air-tight environment. As noted below in greater detail, the vent 1120 (FIG. 3) is positioned relative to the microphone 1270 (FIG. 4) so that flowing air upon fresh air-intake does not cause interference with the microphone 1270. Additionally, the vent 1120 should be flush with the external surface and positioned in the middle of the apparatus 1000 so that, when facing sound, the vent does not provide energy that may be reflected.

Referring first to FIG. 1 and FIG. 3, sound may be captured and/or absorbed or directed from the flow of air caused by speech during use of the apparatus 1000. In a preferred embodiment, sound energy 1 is captured or absorbed via the anechoic chamber 1100 and the anechoic channel 1250 disposed within the handle 1200. Suitably, the anechoic chamber 1100 is adapted to capture air 2 containing sound energy generated by a sound source (not shown), and distribute the air 2 over the inner surface of the chamber 1100 and through the anechoic channel 1250 (i.e., the channel 1250 provides fluid communication between the anechoic chamber 1100 and the ambient). The amount of air being passed over the vocal cords is directly proportionate to voice sound volume.

Still referring to the same figures, the anechoic chamber features an vent 1120 so that air may be supplied to the user without disengaging the device from the users face mouth and ear so that a substantially air-tight seal may remain between the anechoic chamber 1100 and a user's face. The vent 1120 opens under negative pressure within the chamber. The vent 1120 closes under the positive pressure caused by a sound source within the chamber. This inlet preferably allows air 2 to pass into the anechoic chamber 1100. In a preferred embodiment, the inlet is defined by a vent 1120 with triple rubber flex valves in a naturally closed position. The triple valve provides ambient sound insulation/shielding during speech. The rubber flex valves easily open when a breath of fresh air is needed to breathe while speaking. As shown in FIG. 3 and FIG. 1, the anechoic chamber 1100 features contours 1130 for increasing the surface area of its internal side-walls. Preferably, these peak contours are a specific shape to enhance the absorption of low base megahertz frequencies. Further surface area is provided via placing small holes or pores in the contours 1130. In the depicted embodiment those contours are defined by wedges or ridges. Suitably, similar pored contours 1251 may be provided to the inner walls of the anechoic channel 1250. As shown, the contours 1251 cooperate to guide energized air (energized with near field sound energy that was not absorbed or contained in the anechoic chamber 1100) over its surface area and around corners to

physically make the air lose sound wave energy. In a preferred embodiment, the anechoic chamber 1100 and channel 1250 is provided with an air vent 1252 through the handle 1200 so that air that has been de-energized of sound energy may be exhausted to the ambient atmosphere. As shown, the exhausted air 2 from the vent 1251 is directed away from the ear chamber 1300 so that if any sound energy remains in the air, the remnant energy will be directed away from the ear chamber 1300 (FIG. 1) and its speaker.

Still referring to FIGS. 1 and 3, the sidewalls of the anechoic chamber 1100 and anechoic channel 1250 are configured to trap, contain, absorb, direct, and deflect sound energy from air that contacts its surface area. For this purpose, the sidewalls of the anechoic chamber 1100 and channel 1250, the sidewalls are constructed of dense open cell acoustic foam for maximum energy absorption and dissipation. When air contains large amounts of sound energy, some of that energy will inevitably propagate through materials designed to absorb the energy and potentially be released to the ambient atmosphere. In view of this fact, the sidewalls preferably feature layers with various acoustical properties (including energy densities) for further sound absorption and reflection of sound energy back toward the inside of the anechoic chamber 1200 and the user's face. These layers are depicted in FIG. 5, which is a cross section of a typical sidewall.

Referring to FIGS. 5 and 3, the inner walls of the anechoic chamber 1100 and the anechoic channel 1250 are suitably constructed in layers. As shown in FIG. 5: a first layer 1252 may be defined by an anti-microbial sound absorbent coating to maximize bass dampening while not allowing the surfaces in contact with the users saliva to become ridden with bacteria; a second layer 1253 comprised of dense open cell acoustic foam defining the pored contours 1130 and 1251 of the chamber 1100 and channel 1250; a third layer 1254 for defined by a composite (e.g., modeling clay that will not shrink or dry always staying permeable) or foil/metal (e.g., aluminum foil or light gauge sheet metal) for absorbing, deflecting and reflecting energy back to within the anechoic chamber and thru to the channel up to the exhaust 1252; a fourth layer 1255 of dense open cell acoustic foam; a fifth layer 1256 of a composite or foil/metal or clay for absorbing and or reflecting energy; a sixth layer 1257 of large, open cell plastic; and the outer shell of the apparatus 1000. As shown in FIGS. 3 and 5, sound energy 5 is absorbed by the second layer 1253 and, if not, the energy 6 is reflected by the third layer 1254. The second and third layers are important to function because if energy is not adsorbed by the second layer 1253 it is reflected by the third layer 1254. The configuration of functional specific layers of coatings, open cell foam, sheet metal, modeling clay, rubber layers is specifically designed to absorb, contain, reflect and direct the different ranges of frequencies/wavelengths of the sound wave from and male and female speaking, singing and playing a musical instrument, and therefore the combination of these layers, or sets of layers (example: modeling clay backed by thin metal), work to maximize all sound energy absorption and prevent the sound energy from escaping the device.

Referring now to FIG. 4, the upper portion of the handle 1200 features a housing 1260 for retaining the electronics that enable the apparatus to be used in the manner of a telephone handset. This housing 1260 further allows for sound vibration isolation from the anechoic chambers 1100 and sub assembly for manufacturing so the anechoic chamber 1100 is easily assembled in a substantially air tight manner, which may be important to operation of the device. The electronic separation is also needed to direct and expel the electronic heat from

the device. As shown, the housing 1260 retains a battery 1261, a mother circuit board 1262 that is electrically coupled to the phone controls 1210 (including volume controls, on/off controls, and hold microphone button controls), a speaker 1263, a microphone 1270 that is specifically designed to function in a positive air pressure environment, and a receiver/transmitter 1264 (e.g., Bluetooth®) (which may be coupled to the mother circuit board 1262 for receiving and transmitting communications to and from a device (e.g., cell phone, two way radio, or home phone). To vent the naturally occurring build-up of heat from electronic operations, the housing 1260 is outfitted with a vent 1280 for venting heat from the housing 1260. This isolated vent 1280 also allows the devices audio speaker to naturally flex its speaker membrane for clear sound amplification. These phone electronics are configured to operate in the manner of a Bluetooth® or other wireless headset for mobile, home, or office communication devices. 1230 is a 3.5 mm industry standard headphone jack so the device can be wired (linked) to a cell phone without blue tooth. In such configurations the blue tooth components will either be off or not located in the device. As shown, the microphone 1270 is positioned within the anechoic chamber from the housing 1260 so that no saliva generally comes in contact with the users "salvia spray" while speaking. The mic 1270 is also positioned so air from intake 1251 will not cause "noise" air flow interference from incoming air when the user breathes. Suitably, the microphone 1270 is configured for use within a pressurized chamber and with an air tight seal between the anechoic chamber and the housing 1260. In other words, the microphone 1270 is specifically designed to function in a positive air pressure environment. The microphone 1270 may preferably be passed through a housing 1260 via opening 1291 (see FIG. 3). Again, this specific position allows for isolation from the majority of the sound vibrations and also to aid in sub manufacturing assemblies. Finally, weights 1271 and 1272 may be positioned at the upper and lower portions of the apparatus 1000 for balance.

As alluded to above, the apparatus 1000 is designed to be operated in the manner of a telephone handset. FIG. 6 shows an environmental view of the apparatus 1000 in operation. As shown, the apparatus 1000 is operated via placing (1) the mouth opening 1110 securely over the mouth of a user so that the cushioning 1140 or flexible rubber seal of the device 1000 is firmly and comfortably positioned around the mouth of the user and (2) the ear opening 1310 over the ear of a user so that the cushioning 1330 is firmly positioned around or over the ear of a user. Suitably, the anechoic chamber cushioning 1140 or flexible rubber seal is configured to act as an air-tight gasket between the interface of the mouth and anechoic chamber 1100. In one embodiment, the cushioning may be removable, disposable, and replaceable to avoid build-up of dirt, bacteria and other substances that may accumulate during use. FIG. 13 illustrates the positioning of the device over the mouth. Suitably, the mouth opening is generally mouth shaped and curved so that it may be pressed around the mouth of a user and into the soft tissue 5000 (the area indicated by dashed lines) of the face. In a preferred embodiment, the mouth opening must engage the soft tissue of the face so that the mouth piece pushes softly into the face without interfering with the lips so the user has no difficulties speaking and singing normally. This engagement creates a substantially air-tight seal around the mouth of a user and allows the ear chamber 1300 to be properly positioned over the ear. The ear chamber 1300 cushioning 1330 is configured to act as a gasket between the interface of the ear and ear chamber 1200.

Preferably, the apparatus is configured to fit securely over the ear and mouth of a user, without breaking the air tight seal

between the mouth opening **1110** and mouth of a user and the seal between the ear opening **1310** and the ear of a user. Suitably, this is accomplished via positioning the apparatus at a metocervical angle in a range of fifteen and twenty five degrees relative to the face of a user. Other embodiments need not incorporate these angles. A preferable metocervical angle position for the apparatus is about nineteen degrees for female users and about twenty three degrees for male users. These metocervical angle positions result in the appropriate ear to mouth engagement at an eighty-eighth percentile relationship for both of the bitragoin sub-nasal arc and the bitragion-menton arc anthropometric measurements. This insures even/equal user pressure around the entire menton subnasale area (i.e., direct contact area of the entire perimeter of the product's face sound seal) and the center of the ear.

In another embodiment, a device can include an anechoic chamber configured to attach with a conventional phone device. FIG. **12** illustrates a cross section of such an embodiment of the apparatus **1000**. In this embodiment, a cellular phone **100**, such as an iPhone®, may be provided into the apparatus **1000** housing **1260** for retaining the electronics. The shape of the handle **1200** will have to be modified depending on the type of phone being provided to the housing **1260**.

FIG. **7** is a perspective and environmental view of an apparatus **2000** for maintaining the privacy of sound produced by a singer. FIG. **8** is a cross section of apparatus of FIG. **7**. As shown, the apparatus **2000** is generally in the shape of a mask and defined by: (1) an anechoic chamber **2100** with a mouth opening **2110** for engaging a mouth of a user; (2) straps **2200** securing the mask to the face of a user, and (3) external ear phones **2300**.

Referring to FIG. **7** and FIG. **8**, sound may be captured and or absorbed during use of the apparatus **2000**. In a preferred embodiment, sound energy **1** is captured or absorbed via the anechoic chamber **2100** and the anechoic channel **2250** disposed adjacent to the chamber **2100**. Suitably, the anechoic chamber **2100** is adapted to capture air **2** containing sound energy generated by a sound source (e.g., a singer), and distribute the air **2** over the inner surface of the chamber **2100** and through the anechoic channel **2250** (i.e., the channel **2250** provides fluid communication between the anechoic chamber **2100** and the ambient atmosphere). So that air may be energized with sound from within the anechoic chamber **1100**, the anechoic chamber features an air inlet **2120**. This inlet preferably allows air **2** to pass into the anechoic chamber **1100**. In a preferred embodiment, the inlet is defined by a vent **2120** with double rubber flex valves in a naturally closed position. The vent **2120** closes under the positive pressure caused by a sound source within the chamber. As shown in FIG. **7**, the anechoic chamber **2100** features contours **2130** for increasing the surface area of its internal sidewalls. Further surface area is provided via placing small holes or pores in the contours. In the depicted embodiment those contours are defined by wedges or ridges. Suitably, similar contours **2251** may be provided to the inner walls of the anechoic channel **2250**. In a preferred embodiment, the anechoic chamber **2250** is provided with an air vent **2252** through the apparatus **2000** so that air that has been de-energized of sound energy may be exhausted to the ambient atmosphere. Finally, the apparatus **2000** features audio output mechanisms **3300** for providing the sound to the earphones **2300** (FIG. **8**). Suitably, the straps **2200** are engaged with a sufficient pressure to secure the mouth opening over the entire menton-nasal root area (i.e., direct contact area of the entire perimeter of the products face

sound seal). All other aspects operate in the same or analogous manner as those described above in connection with earlier embodiments.

FIG. **9** is a perspective and environmental view of an apparatus **3000** for maintaining the privacy of sound produced by a woodwind instrument. FIG. **10** is a cross section of apparatus of FIG. **9**. As shown, the apparatus **3000** is generally in the shape of a box and defined by an anechoic chamber **3100** with an opening **3110** for engaging a woodwind instrument. FIG. **10** illustrates the inner workings of the sound capturing and/or dissipating components of the apparatus **3000**.

Referring to FIG. **9** and FIG. **10**, sound may be captured and or absorbed during use of the apparatus **3000**. In a preferred embodiment, sound energy **1** is captured or absorbed via the anechoic chamber **3100** and the anechoic channel **3250** disposed adjacent to the chamber **3100**. Suitably, the anechoic chamber **3100** is adapted to capture air **2** containing sound energy generated by a sound source (e.g., a woodwind instrument), and distribute the air **2** over the inner surface of the chamber **3100** and through the anechoic channel **3250** (i.e., the channel **3250** provides fluid communication between the anechoic chamber **3100** and the ambient).

As shown in FIG. **9**, the anechoic chamber **3100** features contours **3130** for increasing the surface area of its internal sidewalls. Further surface area is provided via placing small holes or pores in the contours. In the depicted embodiment those contours are defined by wedges or ridges. Suitably, similar contours **3251** may be provided to the inner walls of the anechoic channel **3250**. In a preferred embodiment, the anechoic chamber **3250** is provided with an air vent **3252** so that air that has been de-energized of sound energy may be exhausted to the ambient. Finally, the apparatus features audio output mechanisms **3300** for providing the sound to the earphones **2300** (FIG. **11**). All other aspects are configured or operate in the same or analogous manner as those described above in connection with earlier embodiments.

Other features will be understood with reference to the drawings. While various embodiments of the method and apparatus have been described above, it should be understood that they have been presented by way of example only, and not of limitation. Likewise, the various diagrams might depict an example of an architectural or other configuration for the disclosed method and apparatus, which is done to aid in understanding the features and functionality that might be included in the method and apparatus. The disclosed method and apparatus is not restricted to the illustrated example architectures or configurations, but the desired features might be implemented using a variety of alternative architectures and configurations. Indeed, it will be apparent to one of skill in the art how alternative functional, logical or physical partitioning and configurations might be implemented to implement the desired features of the disclosed method and apparatus. Also, a multitude of different constituent module names other than those depicted herein might be applied to the various partitions. Additionally, with regard to flow diagrams, operational descriptions and method claims, the order in which the steps are presented herein shall not mandate that various embodiments be implemented to perform the recited functionality in the same order unless the context dictates otherwise.

Although the method and apparatus is described above in terms of various exemplary embodiments and implementations, it should be understood that the various features, aspects and functionality described in one or more of the individual embodiments are not limited in their applicability to the particular embodiment with which they are described, but instead might be applied, alone or in various combinations, to one or more of the other embodiments of the dis-

closed method and apparatus, whether or not such embodiments are described and whether or not such features are presented as being a part of a described embodiment. Thus the breadth and scope of the claimed invention should not be limited by any of the above-described embodiments.

Terms and phrases used in this document, and variations thereof, unless otherwise expressly stated, should be construed as open-ended as opposed to limiting. As examples of the foregoing: the term "including" should be read as meaning "including, without limitation" or the like, the term "example" is used to provide exemplary instances of the item in discussion, not an exhaustive or limiting list thereof, the terms "a" or "an" should be read as meaning "at least one," "one or more," or the like, and adjectives such as "conventional," "traditional," "normal," "standard," "known" and terms of similar meaning should not be construed as limiting the item described to a given time period or to an item available as of a given time, but instead should be read to encompass conventional, traditional, normal, or standard technologies that might be available or known now or at any time in the future. Likewise, where this document refers to technologies that would be apparent or known to one of ordinary skill in the art, such technologies encompass those apparent or known to the skilled artisan now or at any time in the future.

The presence of broadening words and phrases such as "one or more," "at least," "but not limited to" or other like phrases in some instances shall not be read to mean that the narrower case is intended or required in instances where such broadening phrases might be absent. The use of the term "module" does not imply that the components or functionality described or claimed as part of the module are all configured in a common package. Indeed, any or all of the various components of a module, whether control logic or other components, might be combined in a single package or separately maintained and might further be distributed across multiple locations.

Additionally, the various embodiments set forth herein are described in terms of exemplary block diagrams, flow charts and other illustrations. As will become apparent to one of ordinary skill in the art after reading this document, the illustrated embodiments and their various alternatives might be implemented without confinement to the illustrated examples. For example, block diagrams and their accompanying description should not be construed as mandating a particular architecture or configuration.

I claim:

1. A telephone handset comprising:

a handle that defines (a) an anechoic channel with a vent to the ambient atmosphere and (b) a telephone component housing;

an anechoic chamber disposed at a first end of the handle that is in fluid communication with the anechoic channel, said anechoic chamber featuring a mouth opening for engaging a mouth of a user, and a microphone for receiving sounds;

an ear chamber disposed at a second end of the handle with an ear opening for engaging the ear of a user;

a speaker, disposed within the component housing and configured to communicate sound into the ear chamber; means for receiving and transmitting a telephonic communication disposed within the telephone component housing, said means electronically coupled to said speaker and said microphone.

2. The handset of claim 1 wherein the anechoic chamber and anechoic channel are defined by inner walls with contours.

3. The handset of claim 2 wherein the contours feature pores.

4. The handset of claim 3 wherein the contours are provided with an acoustic microbial coating.

5. The handset of claim 4 wherein the inner walls are defined by at least one layer of open cell acoustic foam.

6. The handset of claim 5 wherein the inner walls are further defined by at least one layer of metallic foil.

7. The handset of claim 5 wherein the inner walls are further defined by at least one layer of modeling clay.

8. The handset of claim 6 wherein the inner walls are further defined by at least one layer of modeling clay backed by metallic foil.

9. The handset of claim 2 further comprising a contoured exterior surface.

10. The handset of claim 9 wherein the contoured exterior surface is defined by tessellated polygons with angular offset.

11. The handset of claim 10 wherein the tessellated polygons are hexagons.

12. The handset of claim 11 wherein: the contours feature pores and are provided with an acoustic microbial coating; and, the inner walls are defined by at least one layer of open cell acoustic foam.

13. The handset of claim 2 further wherein the anechoic chamber further comprises an air vent.

14. The handset of claim 13 wherein the vent is configured to open in response to negative pressure within the anechoic chamber and close in response to positive pressure within the anechoic chamber.

15. The handset of claim 2 wherein the handle is configured so that the ear chamber engages the ear of a user while simultaneously engaging the mouth of a user in a substantially air-tight manner.

16. The handset of claim 15 wherein the handle is positioned along the jaw of a user at a metocervical angle in a range of fifteen and twenty five degrees.

17. The handset of claim 16 wherein the handle is positioned along the jaw of a user at a metocervical angle of about nineteen degrees for female users and about twenty three degrees for male users.

18. A method of privately communicating comprising the steps of:

obtaining a telephone handset comprising—

a handle that defines an anechoic channel with a vent to the ambient atmosphere,

an anechoic chamber disposed at a first end of the handle that is in fluid communication with the anechoic channel, said anechoic chamber featuring a mouth opening for engaging a mouth of a user,

an ear chamber disposed at a second end of the handle with an ear opening for engaging the ear of a user; simultaneously engaging the mouth opening and ear opening with a mouth and ear respectively; and,

communicating via the mouth so that air is captured via the anechoic chamber and passed through the anechoic channel.

19. The method of claim 18 wherein the handle is positioned along a jaw at a metocervical angle in a range of fifteen and twenty five degrees after the step of simultaneously engaging the mouth opening and ear opening with a mouth and ear respectively.

20. The method of claim 18 wherein the metocervical angle is about nineteen degrees for female users and about twenty three degrees for male users.