



US009614945B1

(12) **United States Patent**
Moser et al.

(10) **Patent No.:** **US 9,614,945 B1**
(45) **Date of Patent:** **Apr. 4, 2017**

(54) **ANTI-NOISE CANCELING HEADSET AND RELATED METHODS**

(71) Applicant: **Quiet, Inc.**, La Jolla, CA (US)

(72) Inventors: **Scott A. Moser**, La Jolla, CA (US);
Joel Christopher Robertson Scott,
Halifax (CA); **Carlos Francisco**
Montoya-Mejia, Spring Valley, CA
(US)

(*) Notice: Subject to any disclaimer, the term of this patent is extended or adjusted under 35 U.S.C. 154(b) by 0 days.

(21) Appl. No.: **15/364,254**

(22) Filed: **Nov. 29, 2016**

Related U.S. Application Data

(63) Continuation-in-part of application No. 14/979,265, filed on Dec. 22, 2015, now Pat. No. 9,525,765, which is a continuation-in-part of application No. 14/943,856, filed on Nov. 17, 2015, now Pat. No. 9,386,135, and a continuation-in-part of application No. 14/740,129, filed on Jun. 15, 2015, now Pat. No. 9,253,299, and a continuation-in-part of application No. 14/577,839, filed on Dec. 19, 2014, now Pat. No. 9,576,567, said application No. 14/943,856 is a continuation-in-part of application No. 14/740,129, filed on Jun. 15, 2015, now Pat. No. 9,253,299, which is a continuation-in-part of application No. 14/577,839, filed on Dec. 19, 2014, now Pat. No. (Continued)

(51) **Int. Cl.**
H04M 1/00 (2006.01)
H04M 9/00 (2006.01)
H04M 1/19 (2006.01)
H04M 1/03 (2006.01)

H04M 1/05 (2006.01)
G10K 11/178 (2006.01)
(52) **U.S. Cl.**
CPC **H04M 1/19** (2013.01); **H04M 1/035** (2013.01); **H04M 1/05** (2013.01); **G10K 11/1788** (2013.01); **G10K 2210/1081** (2013.01)
(58) **Field of Classification Search**
CPC **H04M 1/19**; **H04M 1/035**; **H04M 1/05**; **G10K 11/1788**; **G10K 2210/1081**
See application file for complete search history.

(56) **References Cited**
U.S. PATENT DOCUMENTS
1,800,234 A 4/1931 Tuttle
2,160,229 A 5/1939 Rupert
(Continued)

FOREIGN PATENT DOCUMENTS
CN 2262732 Y 9/1997
CN 1949363 A 4/2007
(Continued)

Primary Examiner — Tuan D Nguyen
(74) *Attorney, Agent, or Firm* — Buche & Associates, P.C.; John K. Buche; Bryce A. Johnson

(57) **ABSTRACT**
Disclosed is a telephone headset that features an antiphase/anti-noise speaker within an anechoic chamber so that noises provided therein can be combated with antiphase noises. In some embodiment, the antiphase/anti-noise speaker can be an exciter. In some embodiments, the headset is designed to include passive and active noise cancellation of a user's voice. Suitably, the headset can be adjusted to fit an inclusive range of head dimensions comfortably, the headsets may connect wirelessly to the user's phone to ensure cable free operation and communication.

20 Claims, 26 Drawing Sheets

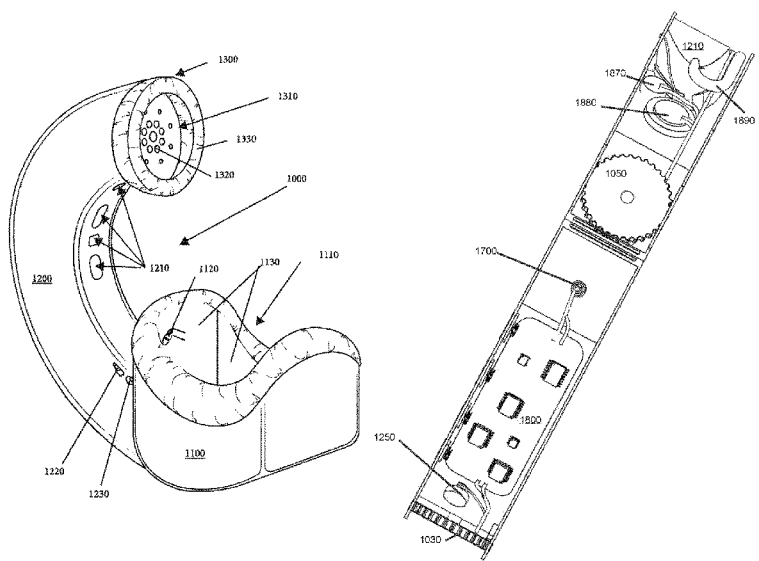

Related U.S. Application Data

9,576,567, which is a continuation-in-part of application No. 14/280,523, filed on May 16, 2014, now Pat. No. 8,948,411, said application No. 14/943,856 is a continuation-in-part of application No. 14/577,839, filed on Dec. 19, 2014, now Pat. No. 9,576,567.

- (60) Provisional application No. 61/949,239, filed on Mar. 7, 2014, provisional application No. 61/949,234, filed on Mar. 6, 2014, provisional application No. 61/941,306, filed on Feb. 18, 2014.

References Cited

U.S. PATENT DOCUMENTS

2,479,806	A	8/1949	Berkley	
2,625,615	A	1/1952	Webb	
2,657,609	A	11/1953	Strobach	
3,796,842	A	3/1974	Guille	
4,396,089	A	8/1983	Scully	
4,782,527	A *	11/1988	Williamson H04M 1/05 379/430
4,792,013	A	12/1988	Boynton	
4,890,688	A	1/1990	Baker	
4,932,495	A	6/1990	Chapman	
4,998,959	A	3/1991	Purdie	
5,778,062	A	7/1998	Vanmoor	
6,320,959	B1	11/2001	Crouch et al.	
6,401,860	B1	6/2002	Ellington et al.	

6,510,311	B1	1/2003	Stitt	
7,197,140	B2	3/2007	Asaro	
7,298,859	B1 *	11/2007	Worley H04M 1/035 379/433.03
7,515,708	B1	4/2009	Doty, III et al.	
7,532,719	B2	5/2009	Snodgrass	
7,564,968	B2	7/2009	Ayers et al.	
7,783,034	B2	8/2010	Manne	
8,243,944	B2	8/2012	Almagro	
8,532,987	B2	9/2013	Holzrichter	
2002/0077838	A1	6/2002	Dutta	
2006/0293091	A1 *	12/2006	Hawker H04M 1/03 455/575.1
2007/0127659	A1	6/2007	McClory et al.	
2009/0169041	A1 *	7/2009	Zurek H04M 1/035 381/345
2011/0136535	A1	6/2011	DiPasquale et al.	
2012/0029912	A1	2/2012	Almagro	
2012/0095768	A1	4/2012	McClung et al.	
2013/0276615	A1	10/2013	Antaki	

FOREIGN PATENT DOCUMENTS

DE	19722045	7/1998
EP	0637188 A1	2/1995
EP	0831453 A3	3/1997
EP	2674048	12/2013
WO	WO9914733	3/1999
WO	PCT/US14/73080	4/2015

* cited by examiner

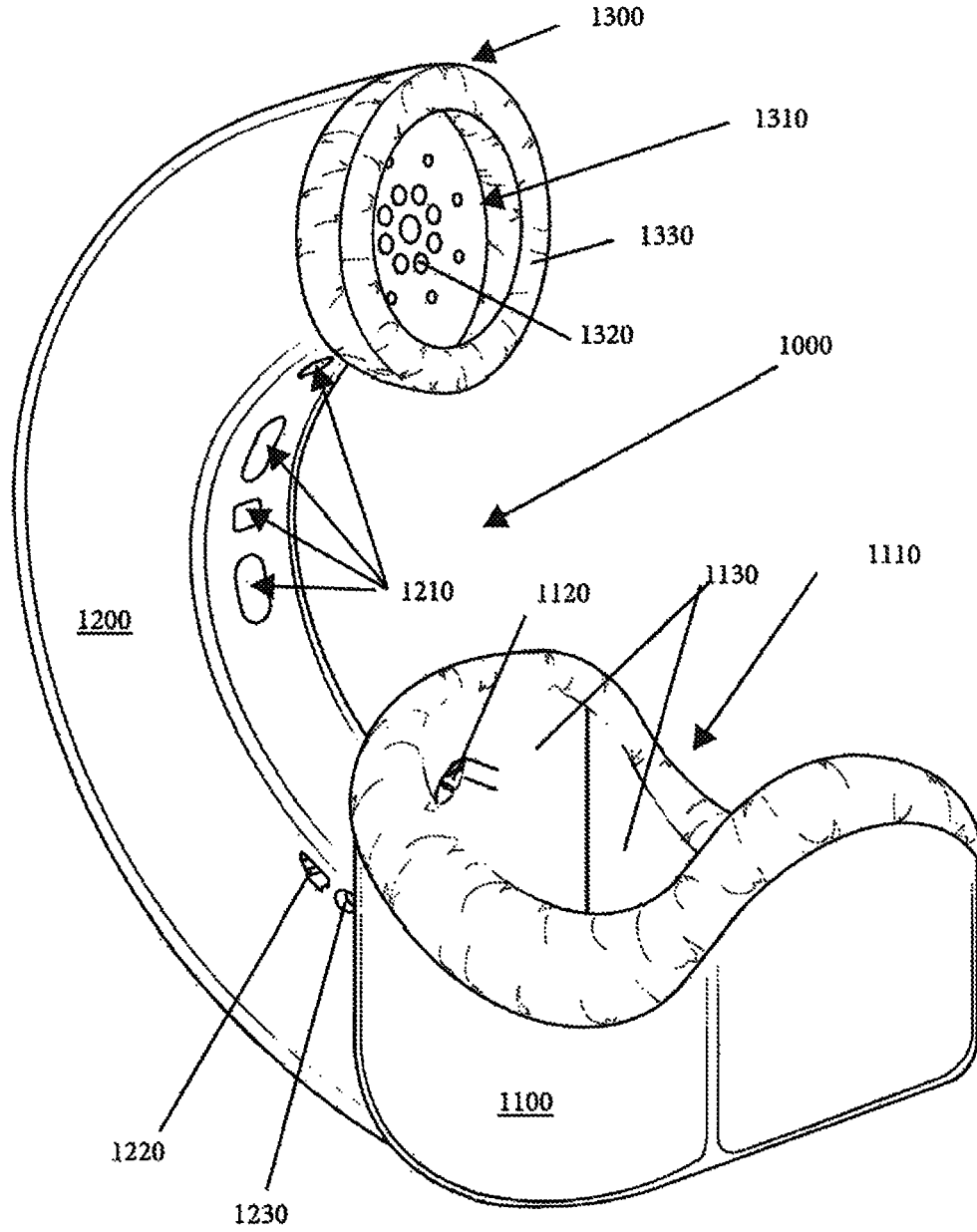

FIG. 1

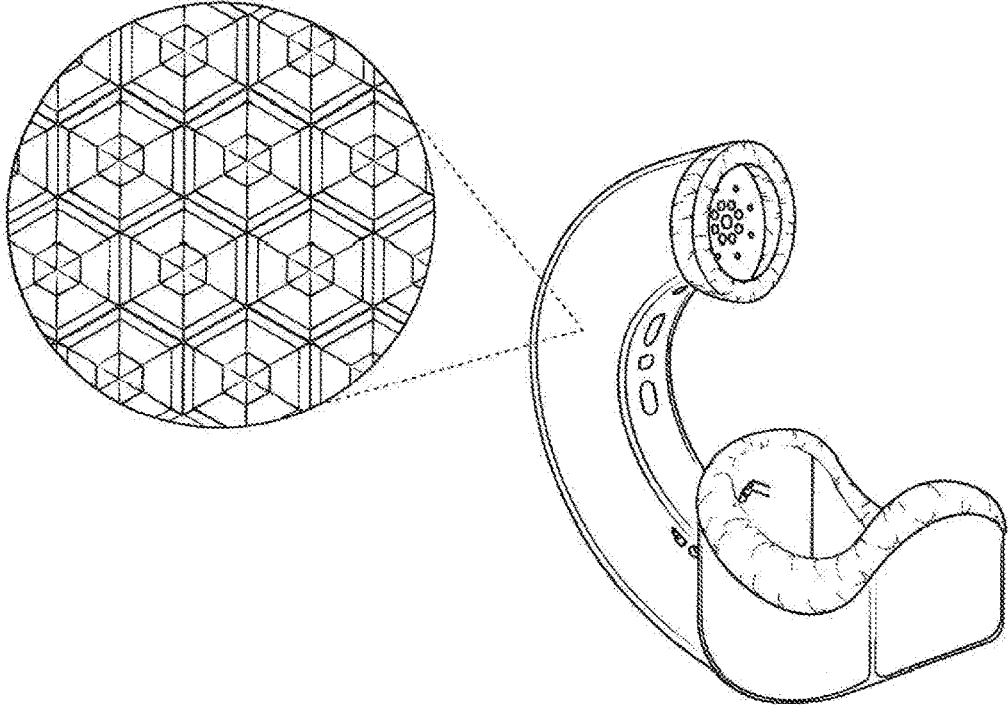

FIG. 2

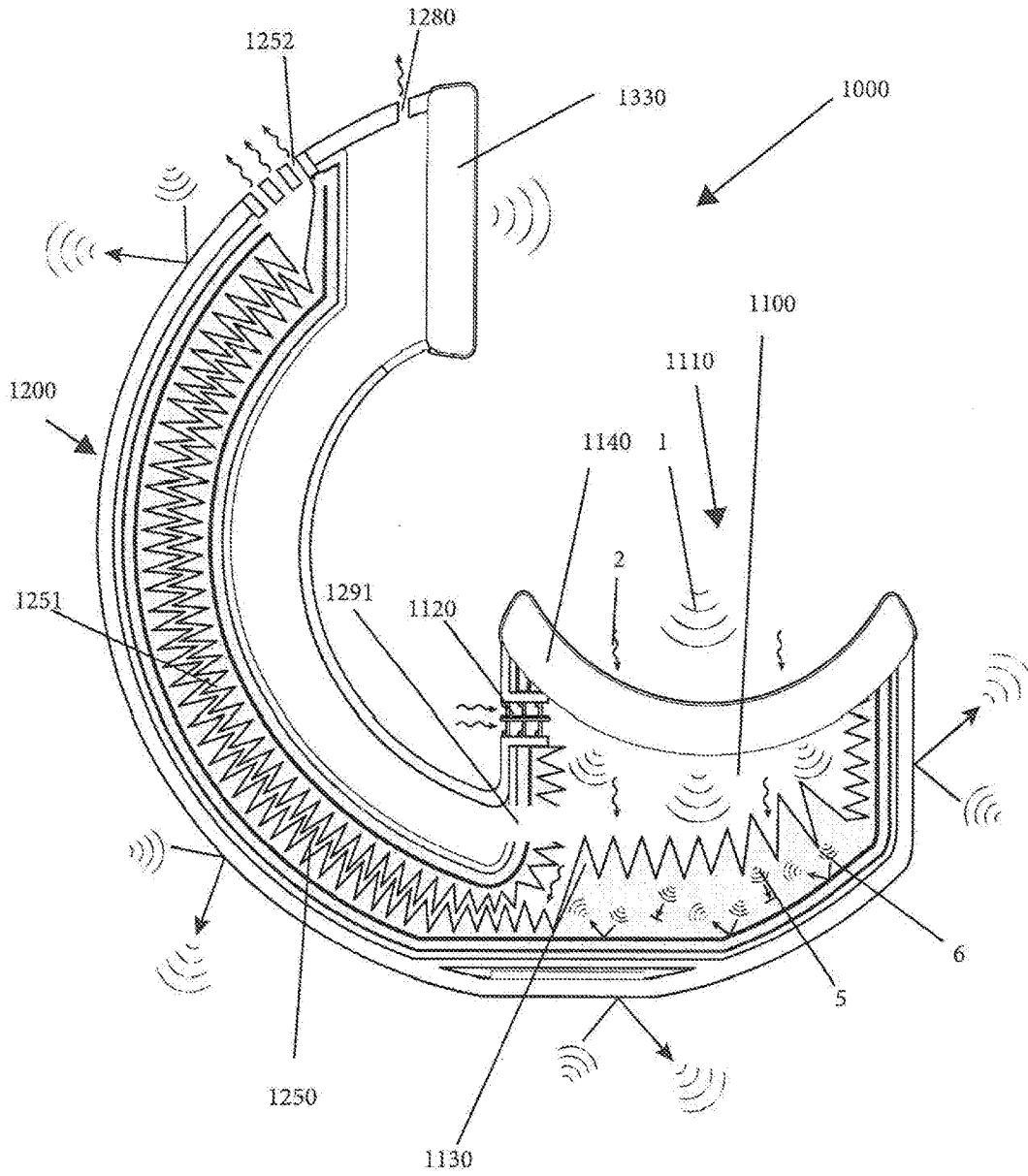

FIG. 3

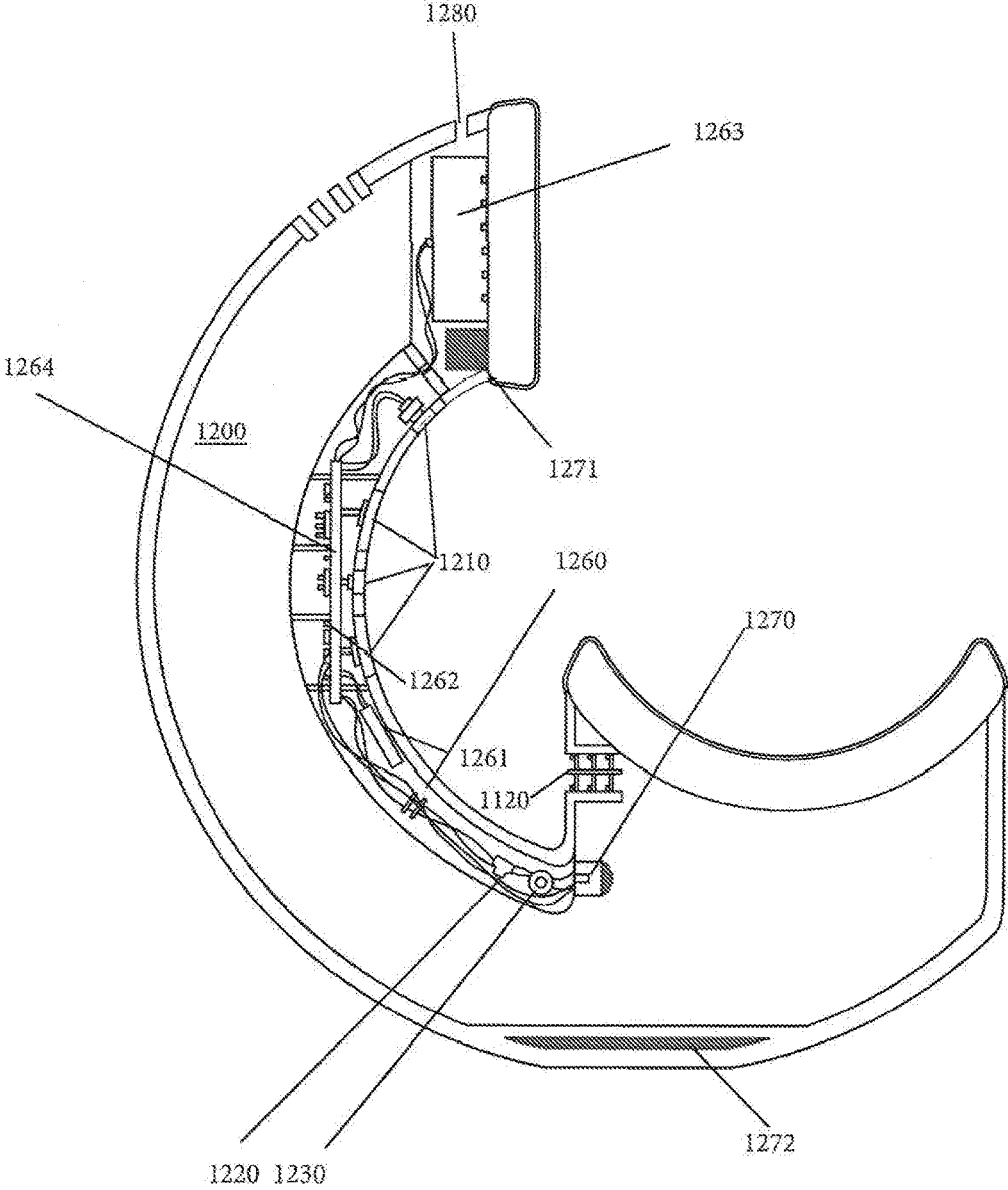

FIG. 4

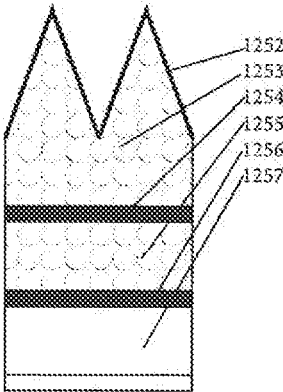

FIG. 5

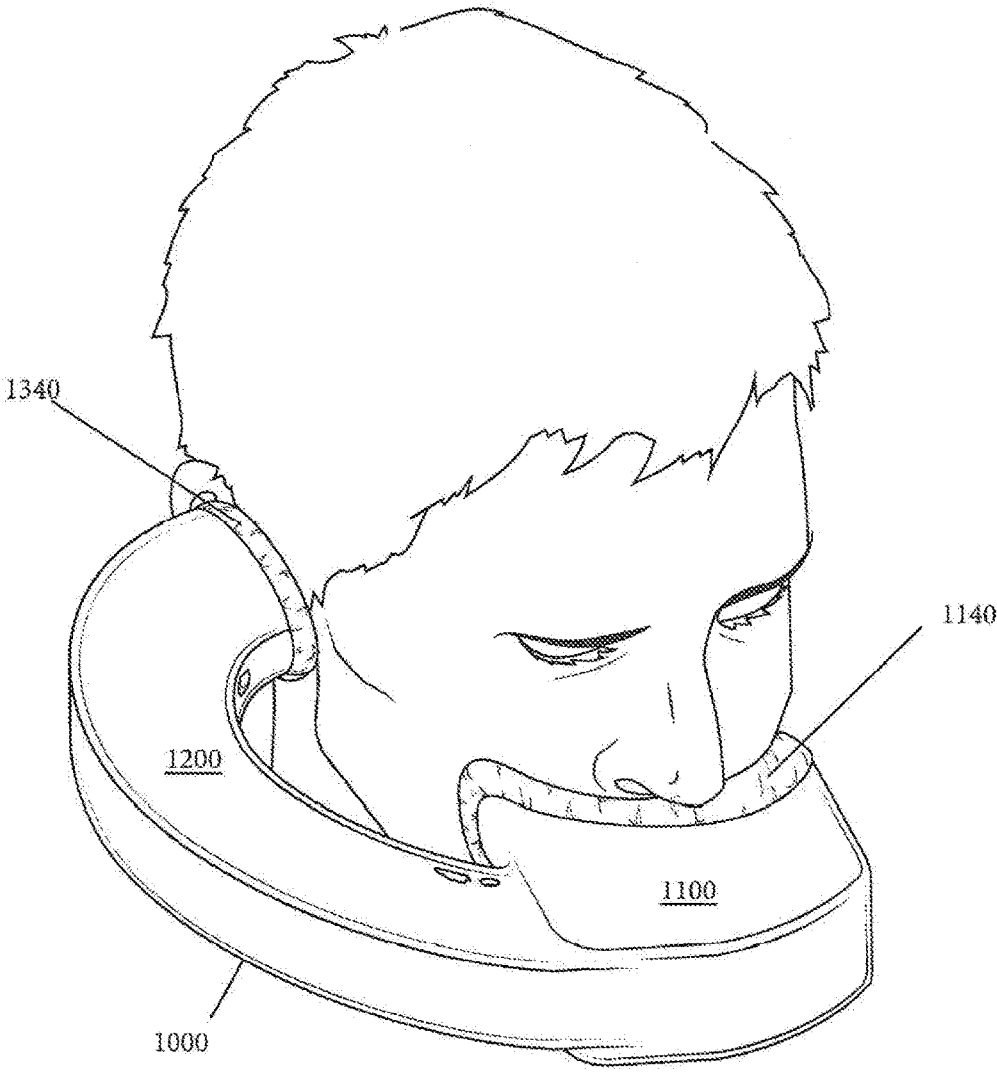

FIG. 6

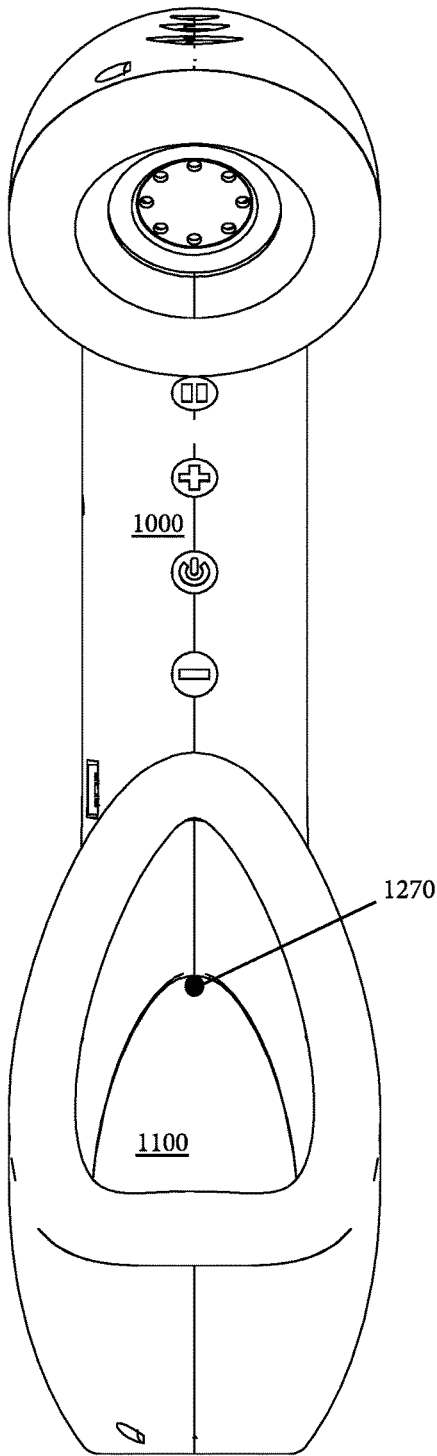

FIG. 7

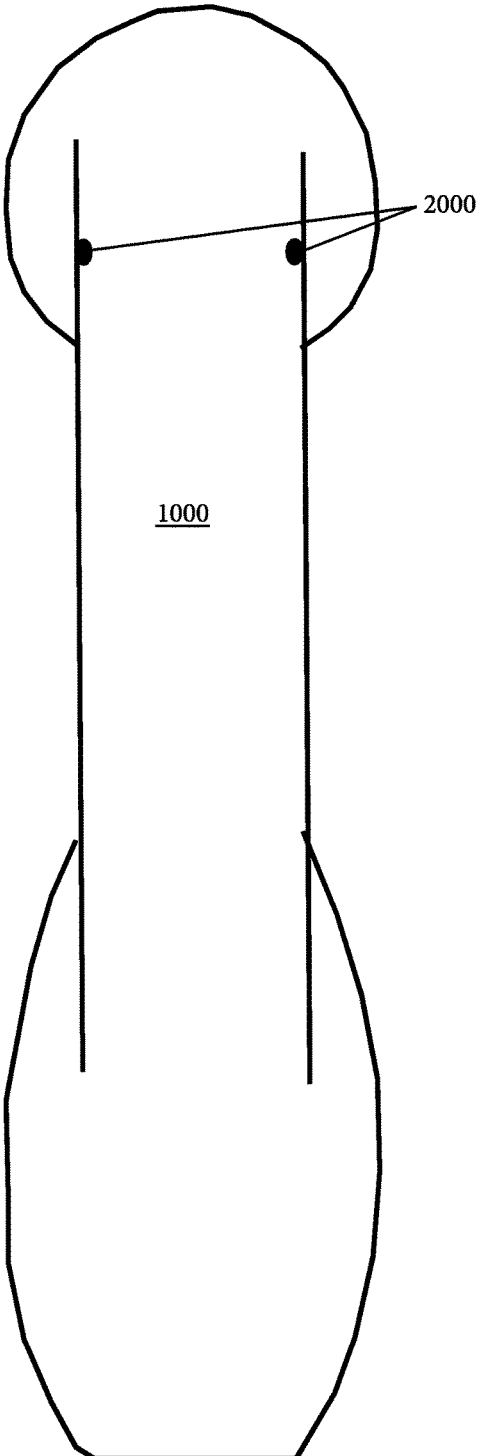

FIG. 8

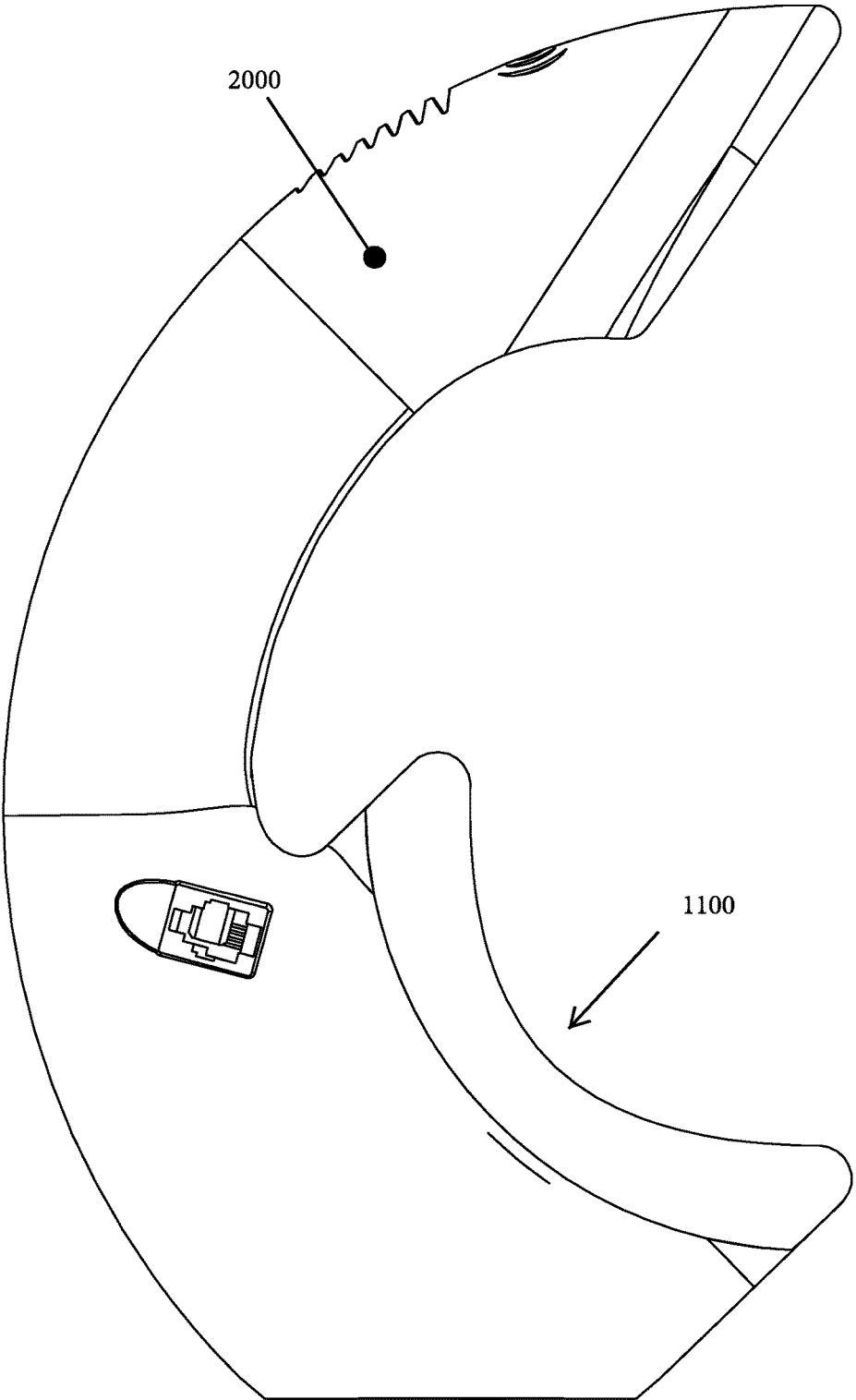

FIG. 9

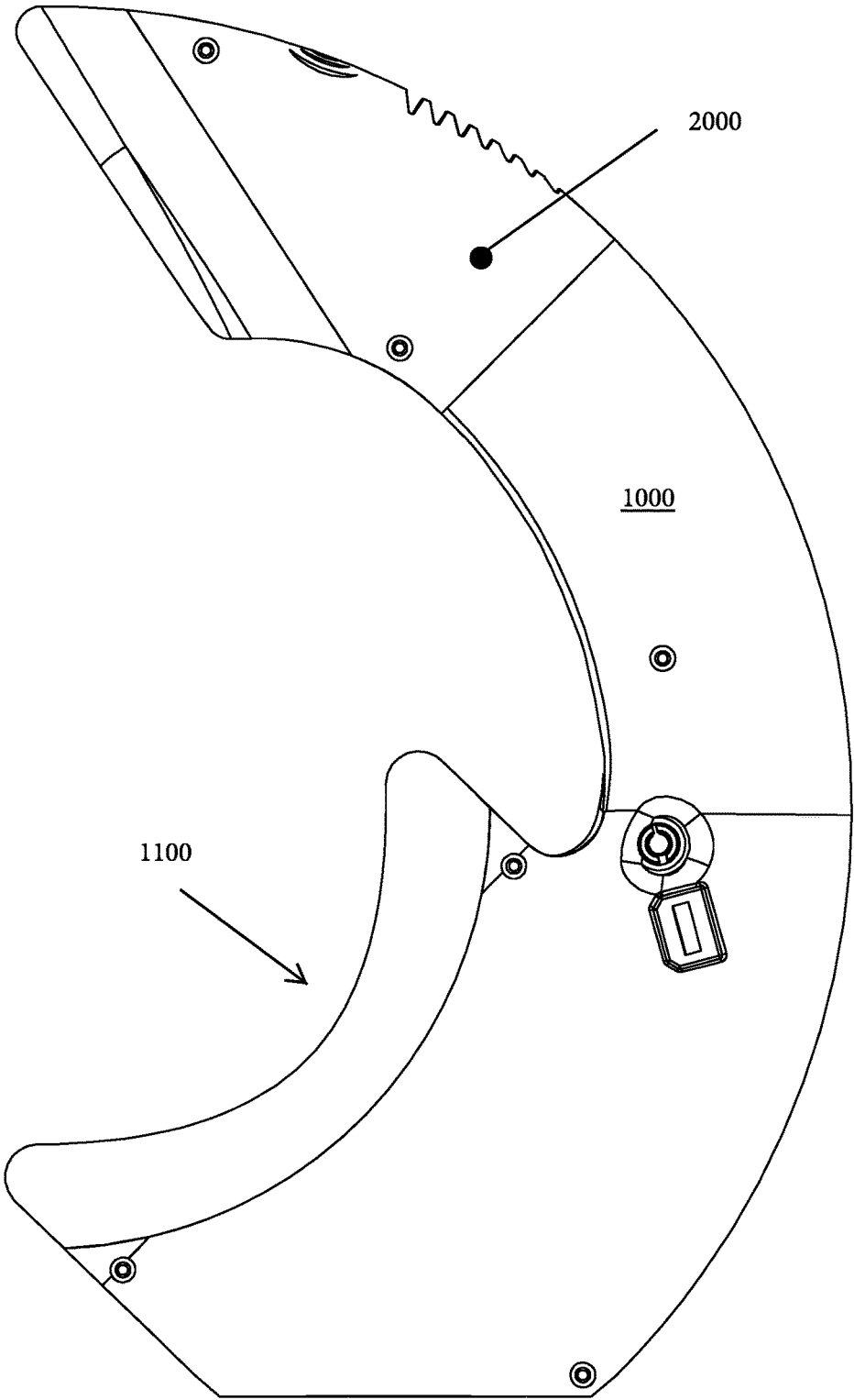

FIG. 10

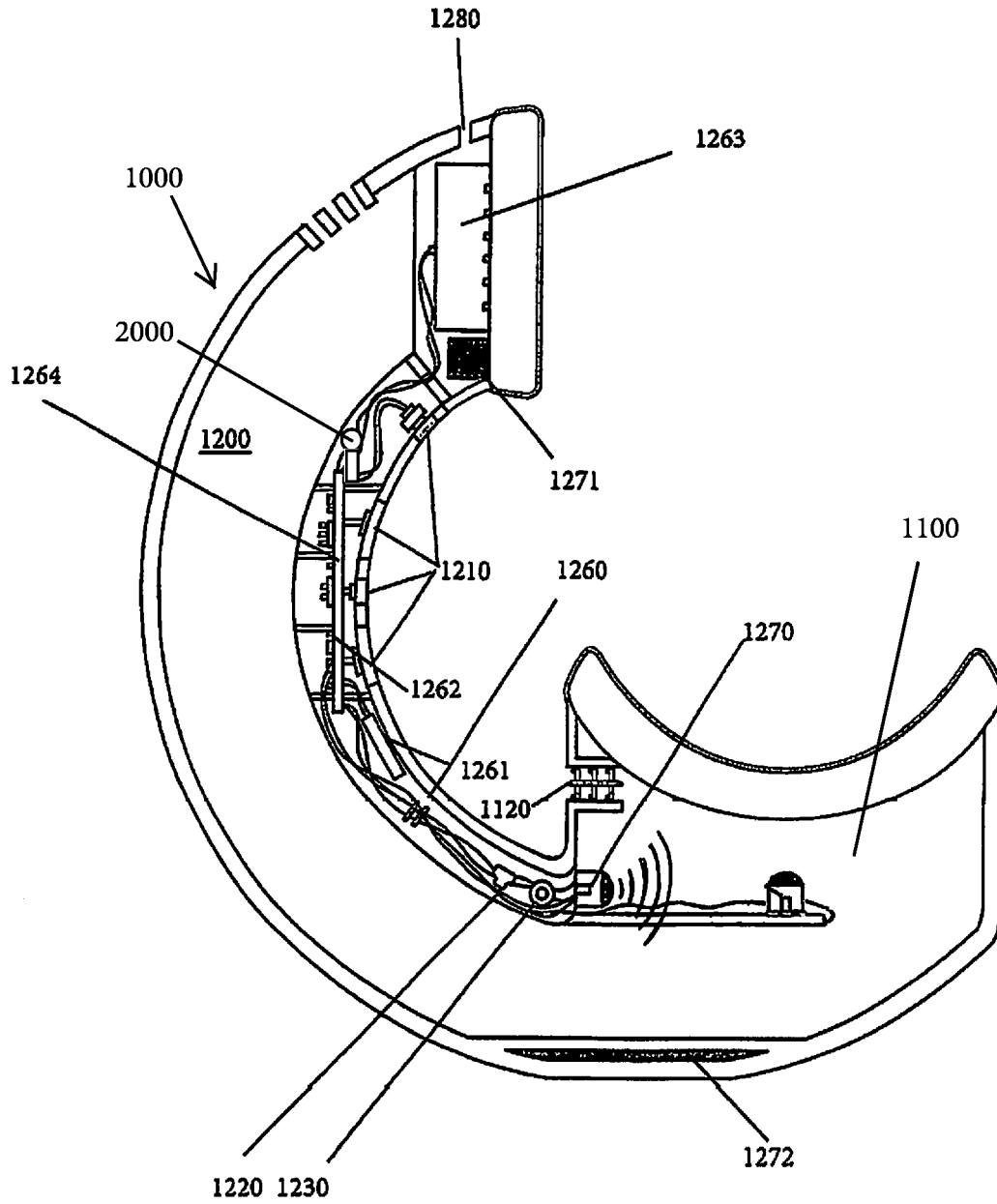

FIG. 11

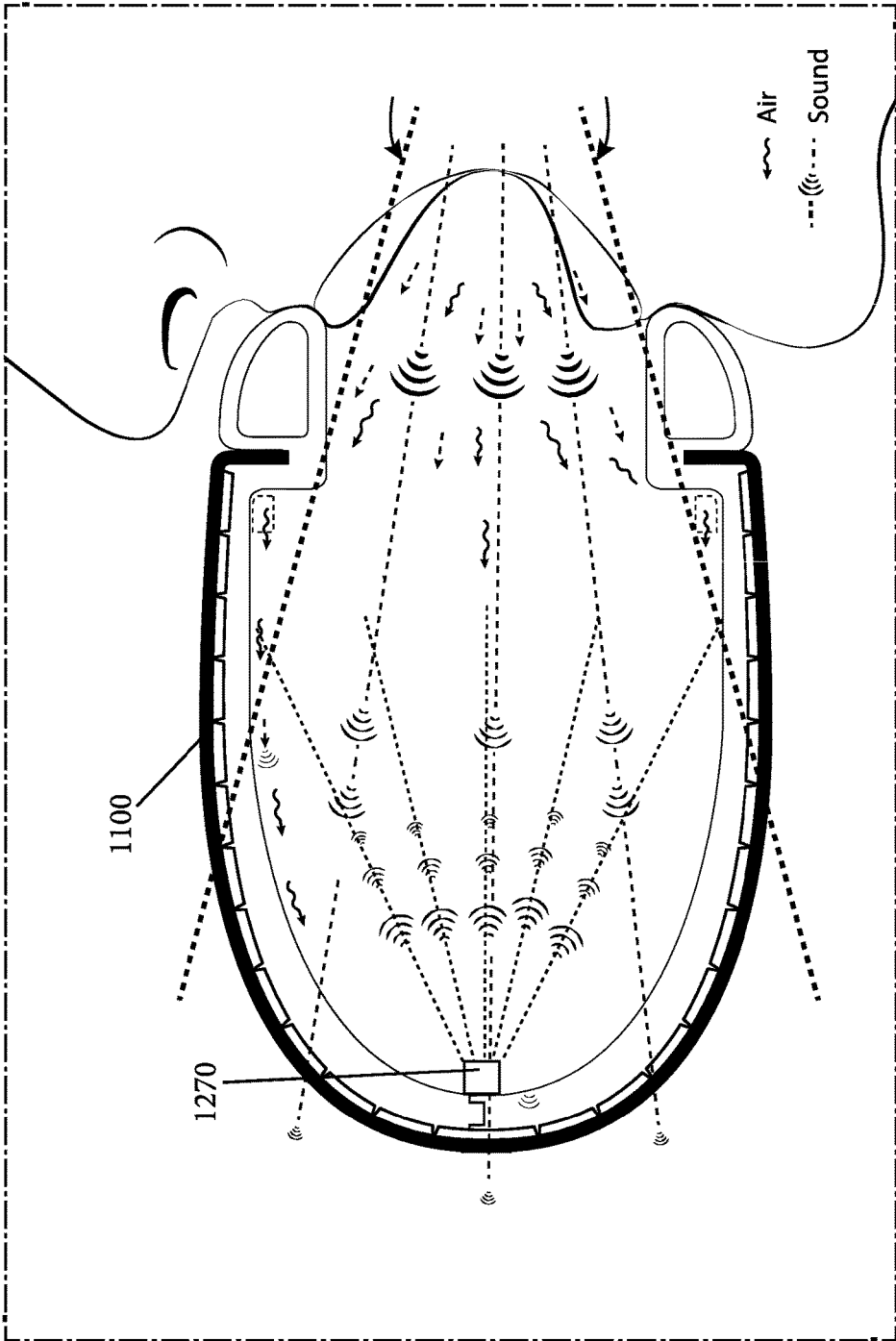

FIG. 12

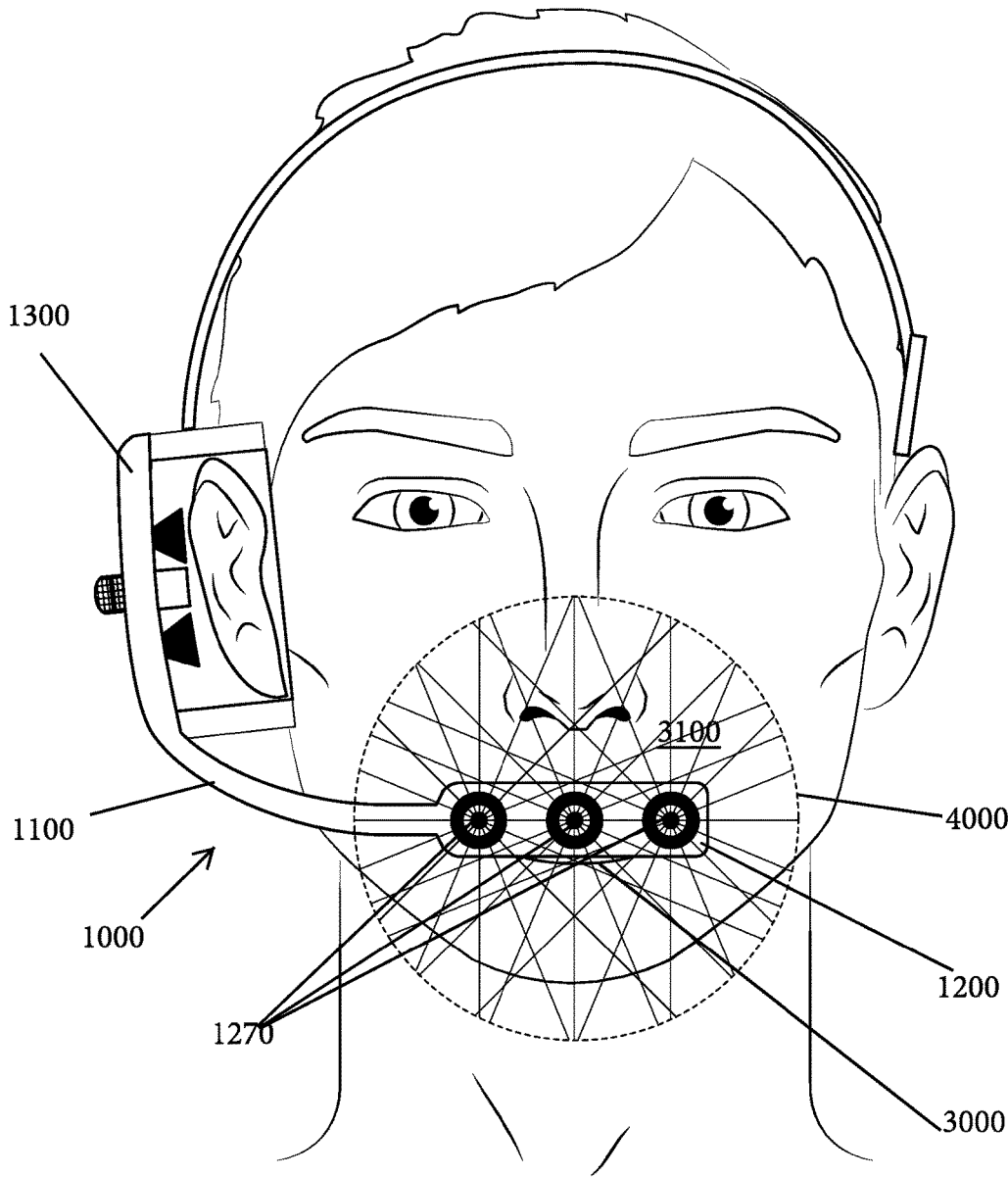

FIG. 13

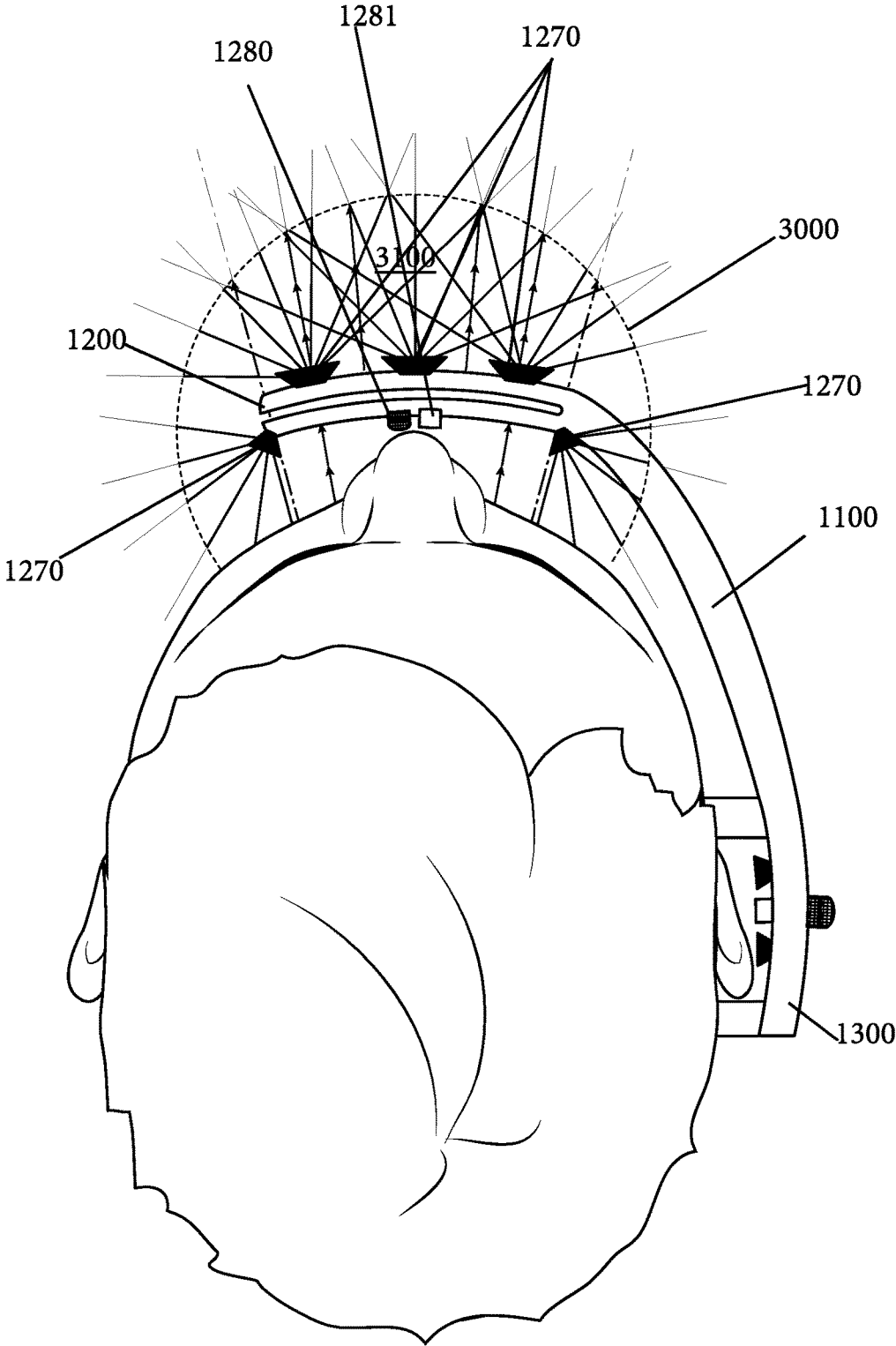

FIG. 14

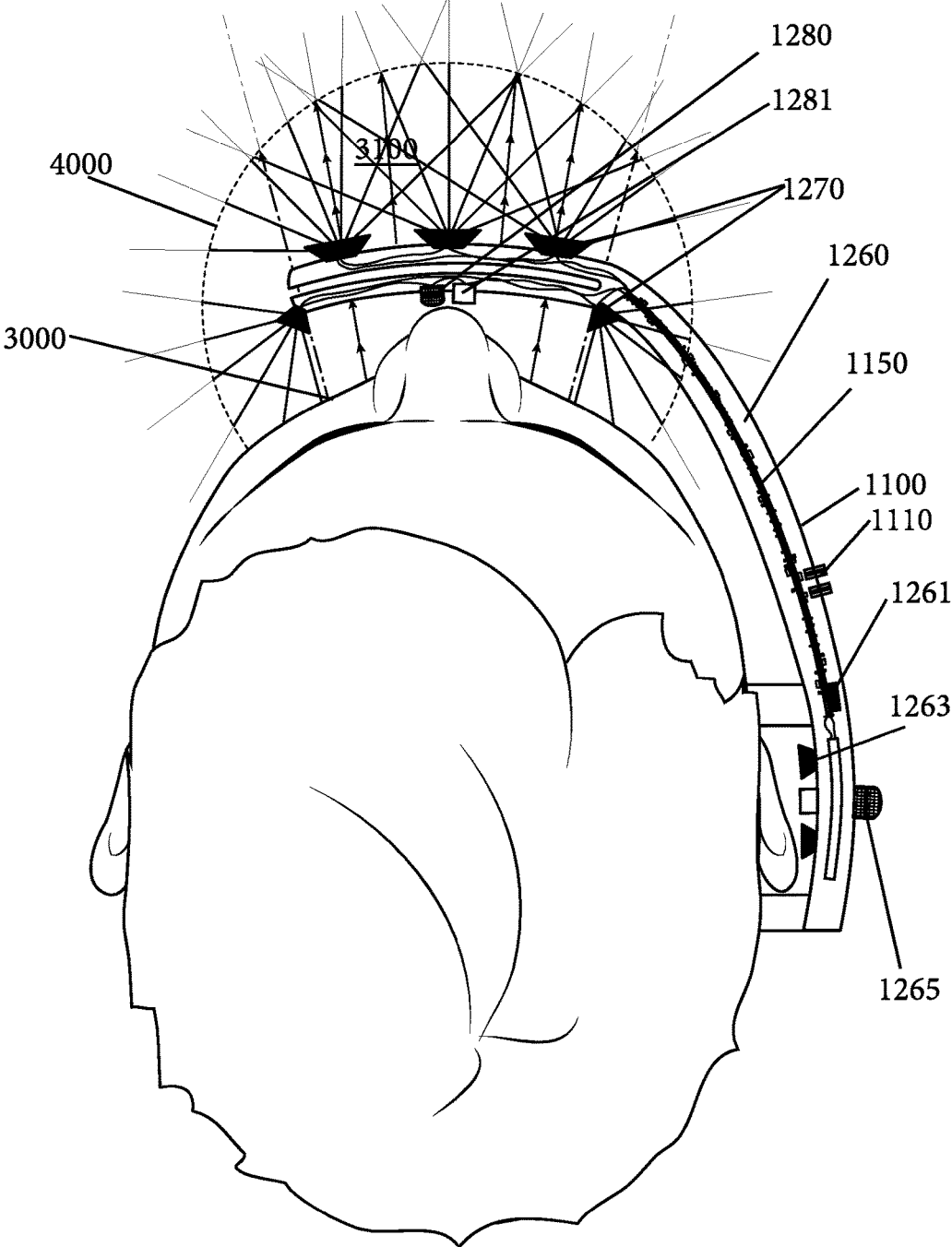

FIG. 15

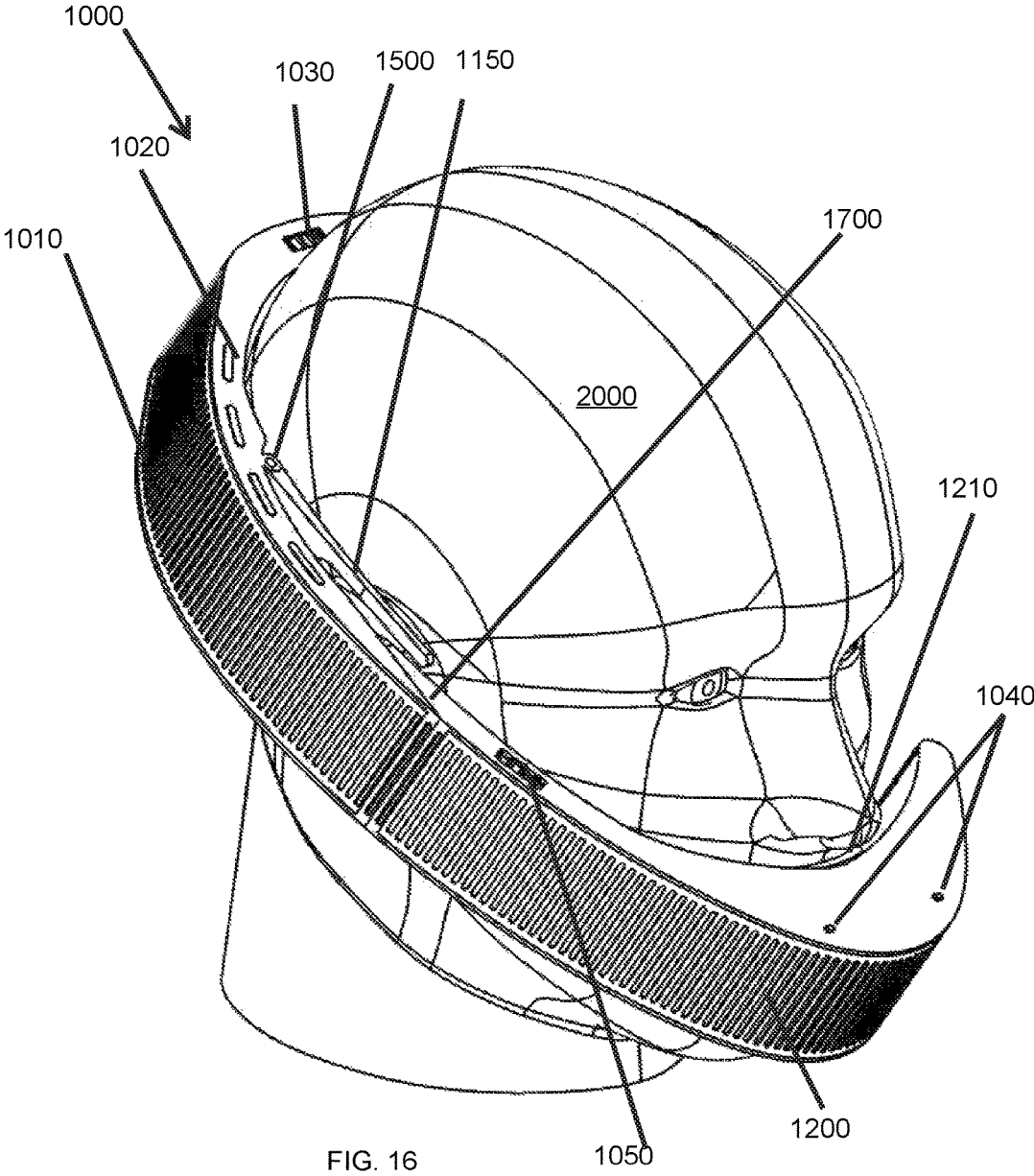

FIG. 16

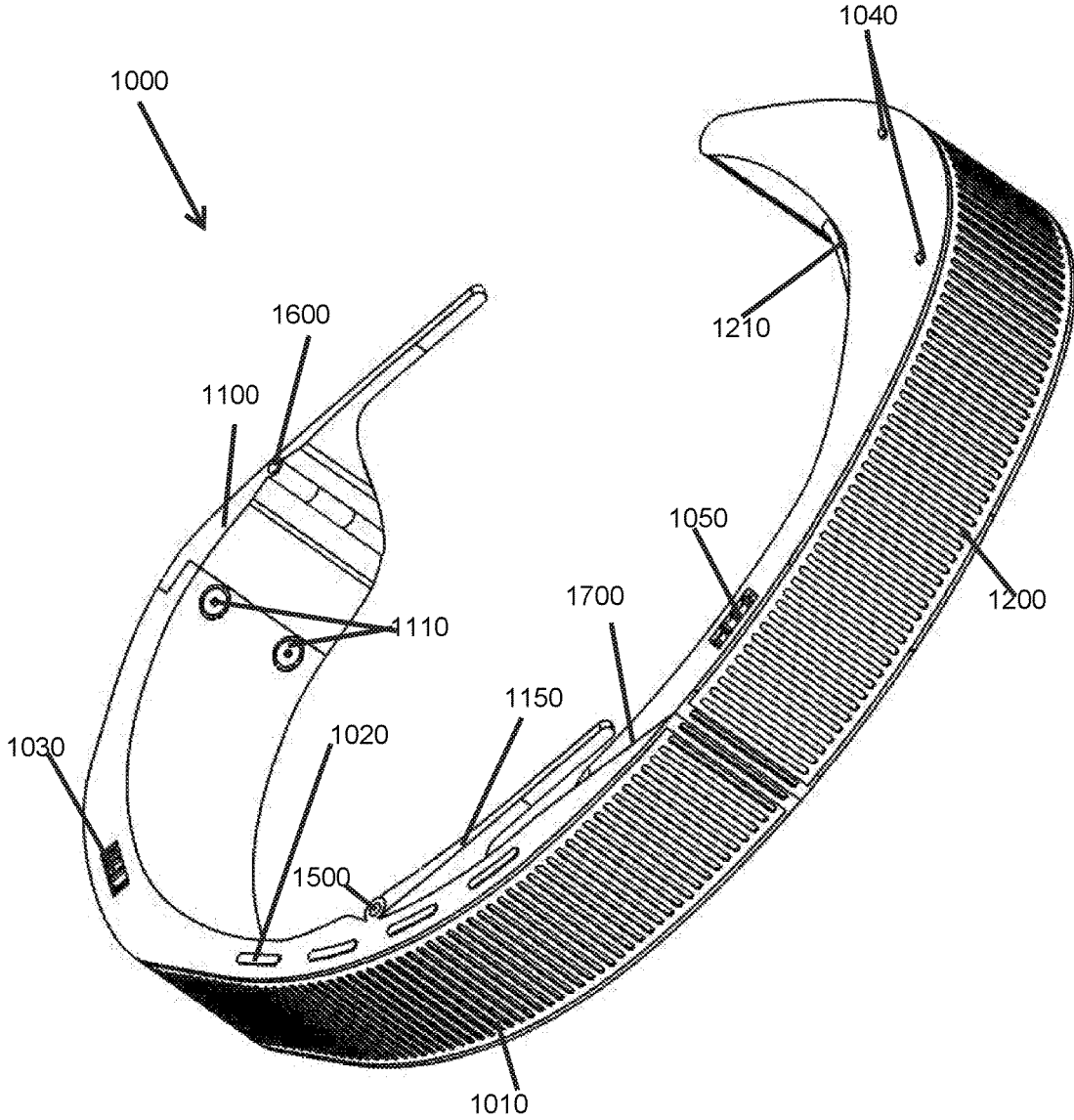

FIG. 17

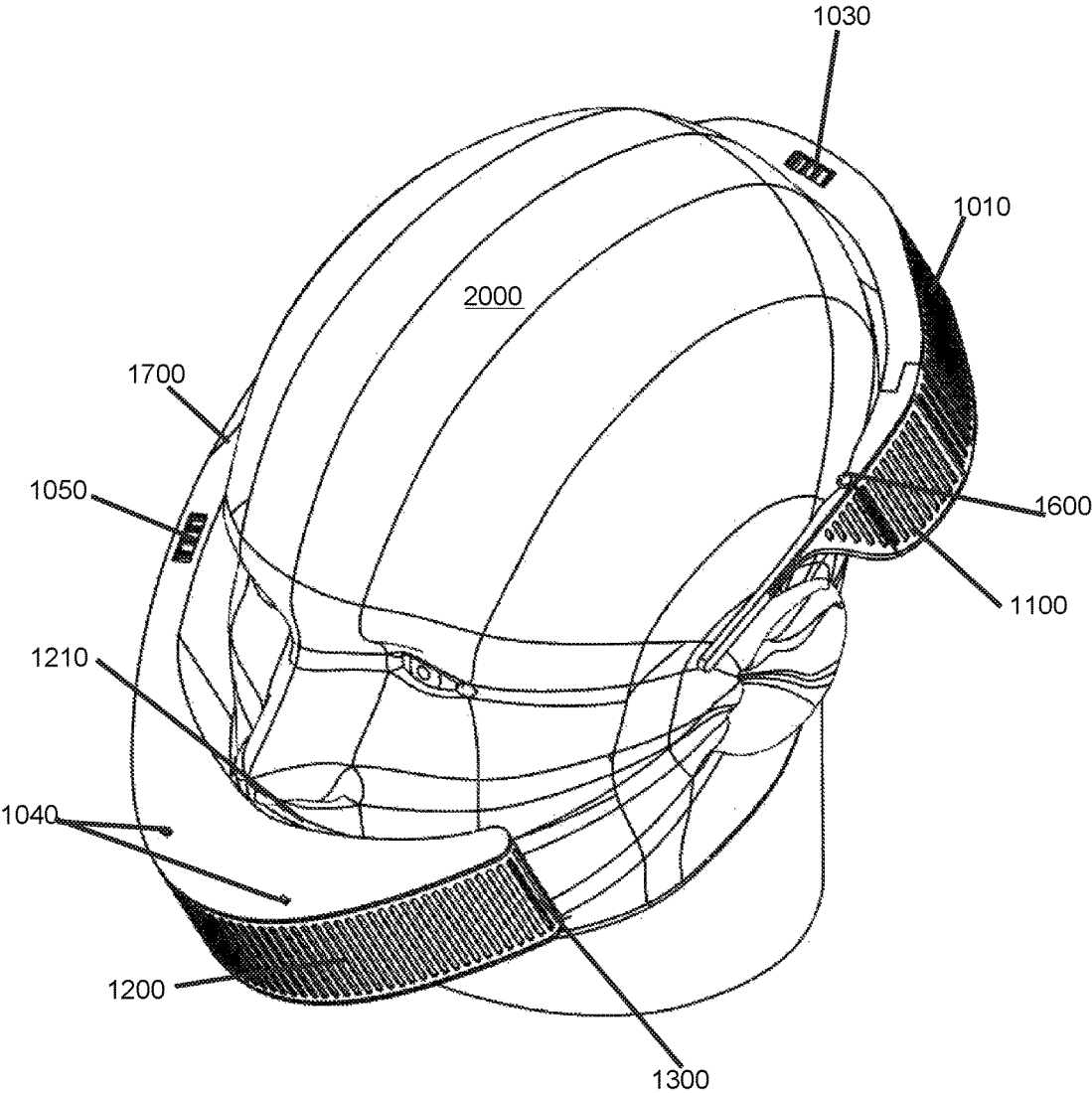

FIG. 18

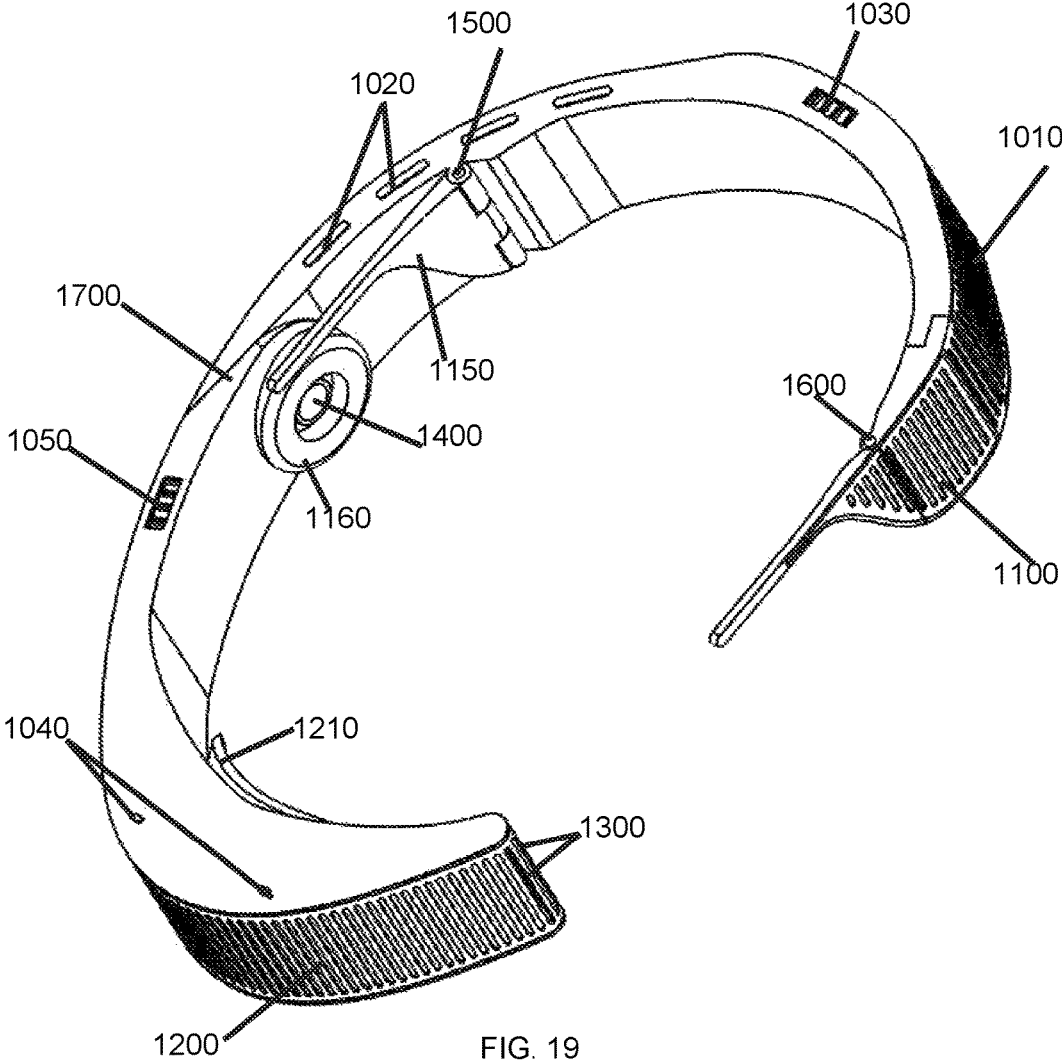

FIG. 19

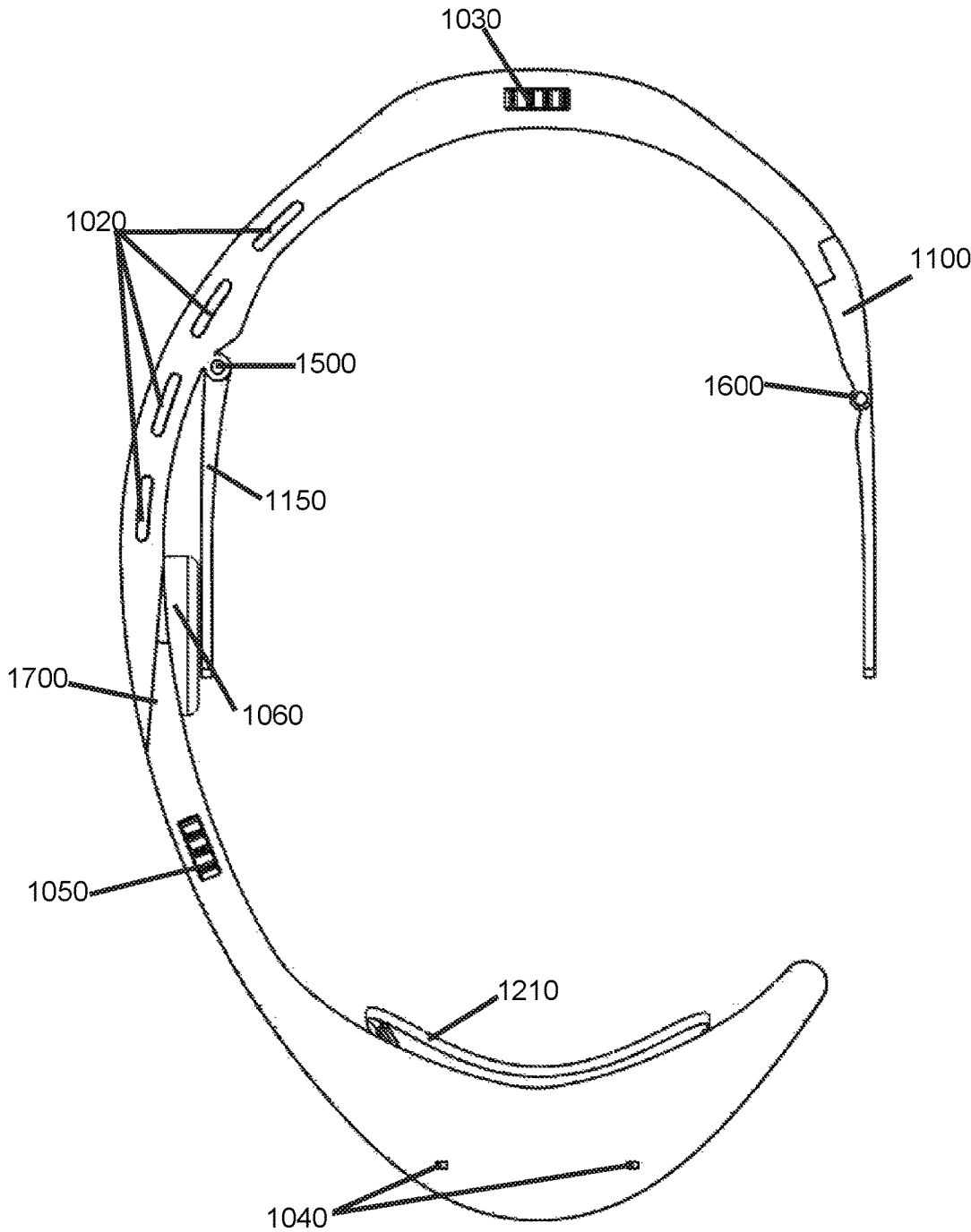

FIG. 20

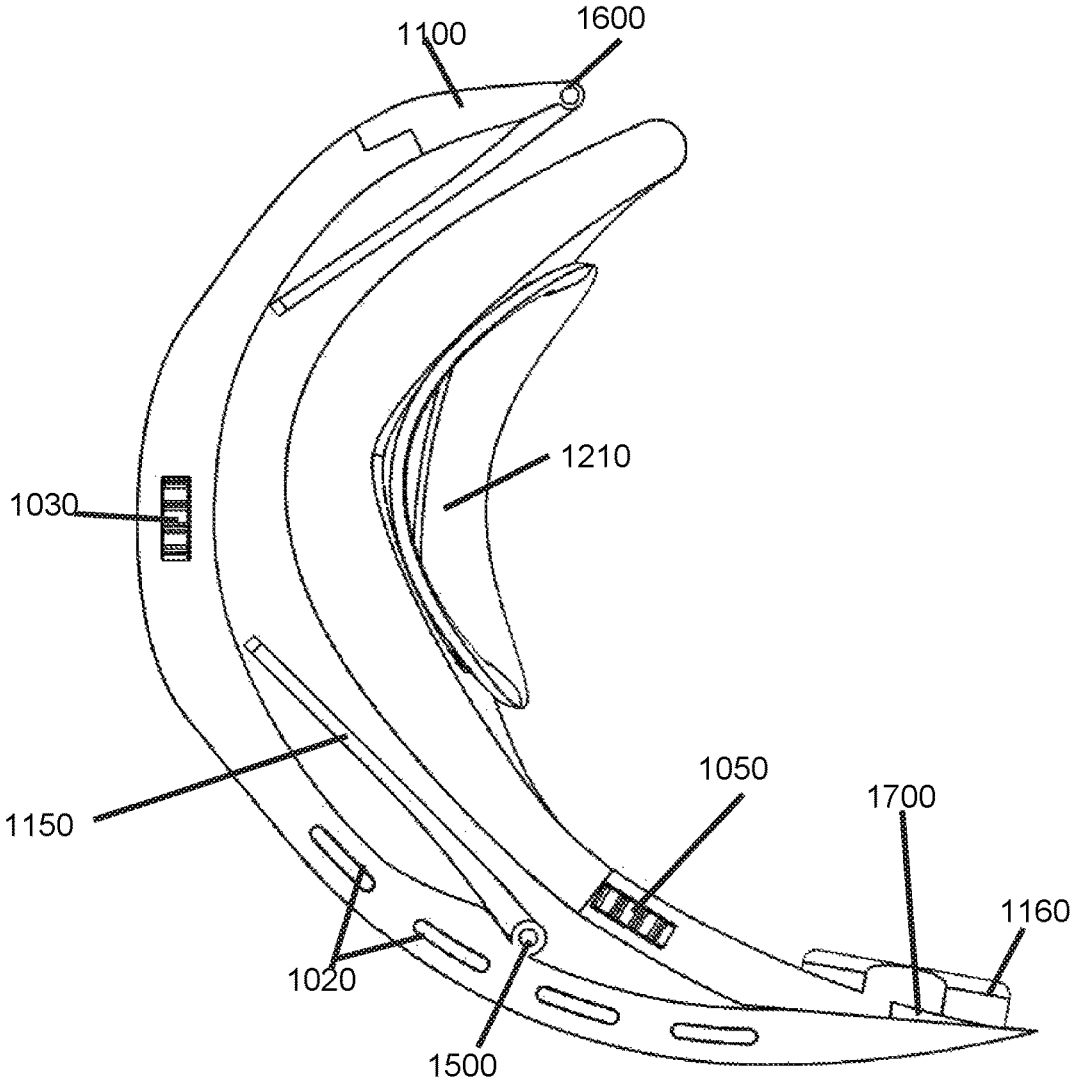

FIG. 21

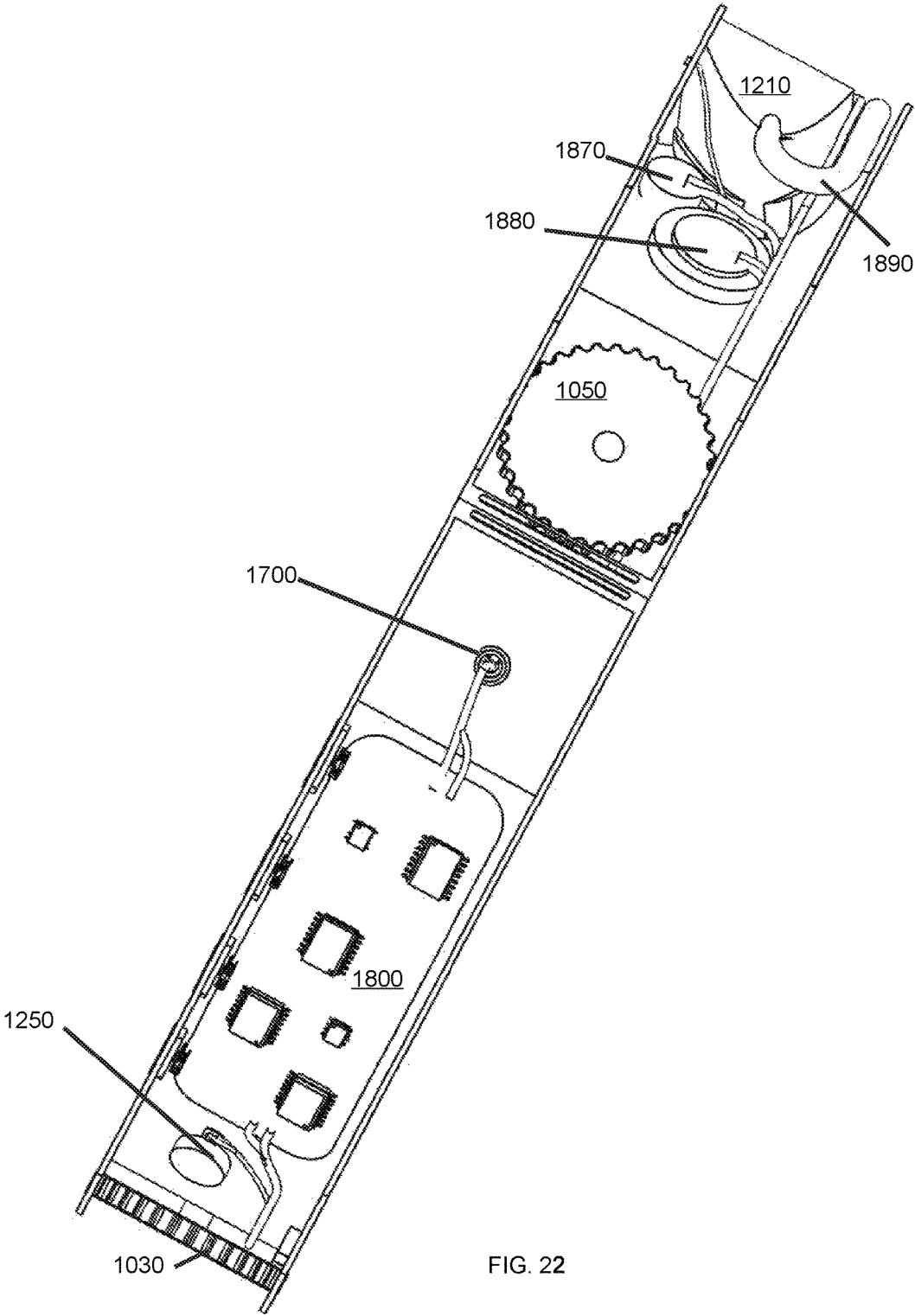

FIG. 22

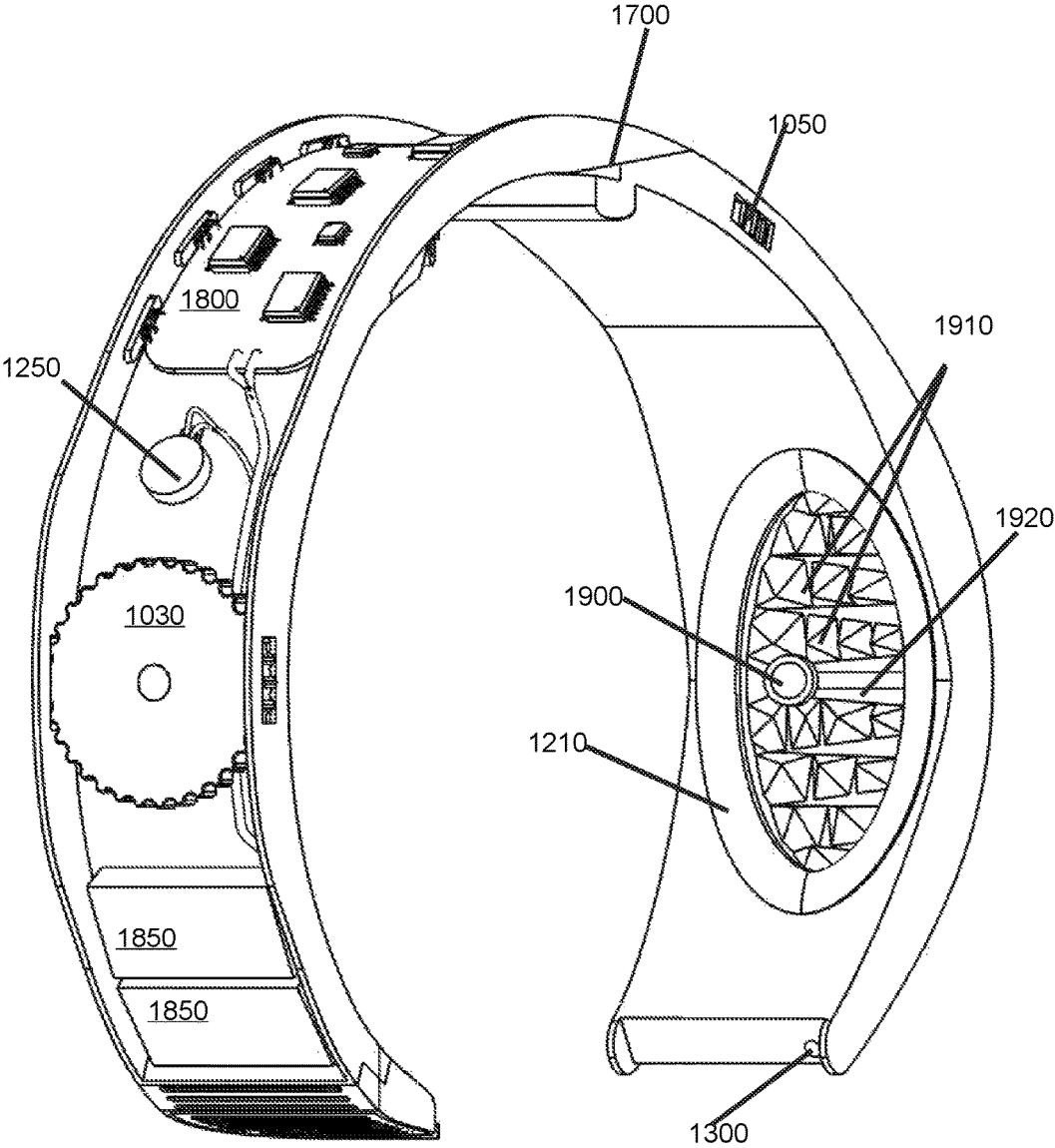

FIG. 23A

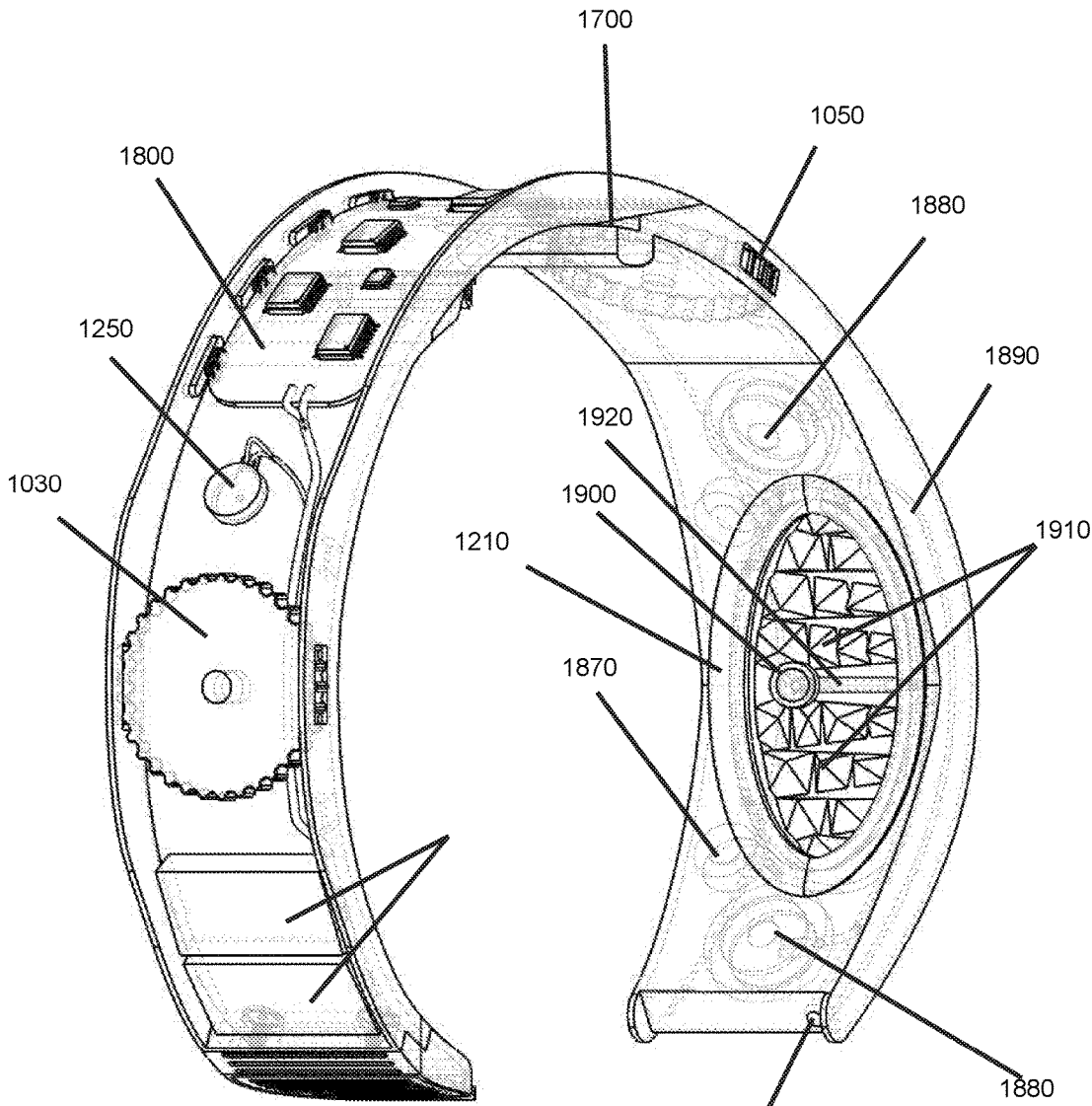

FIG. 23B

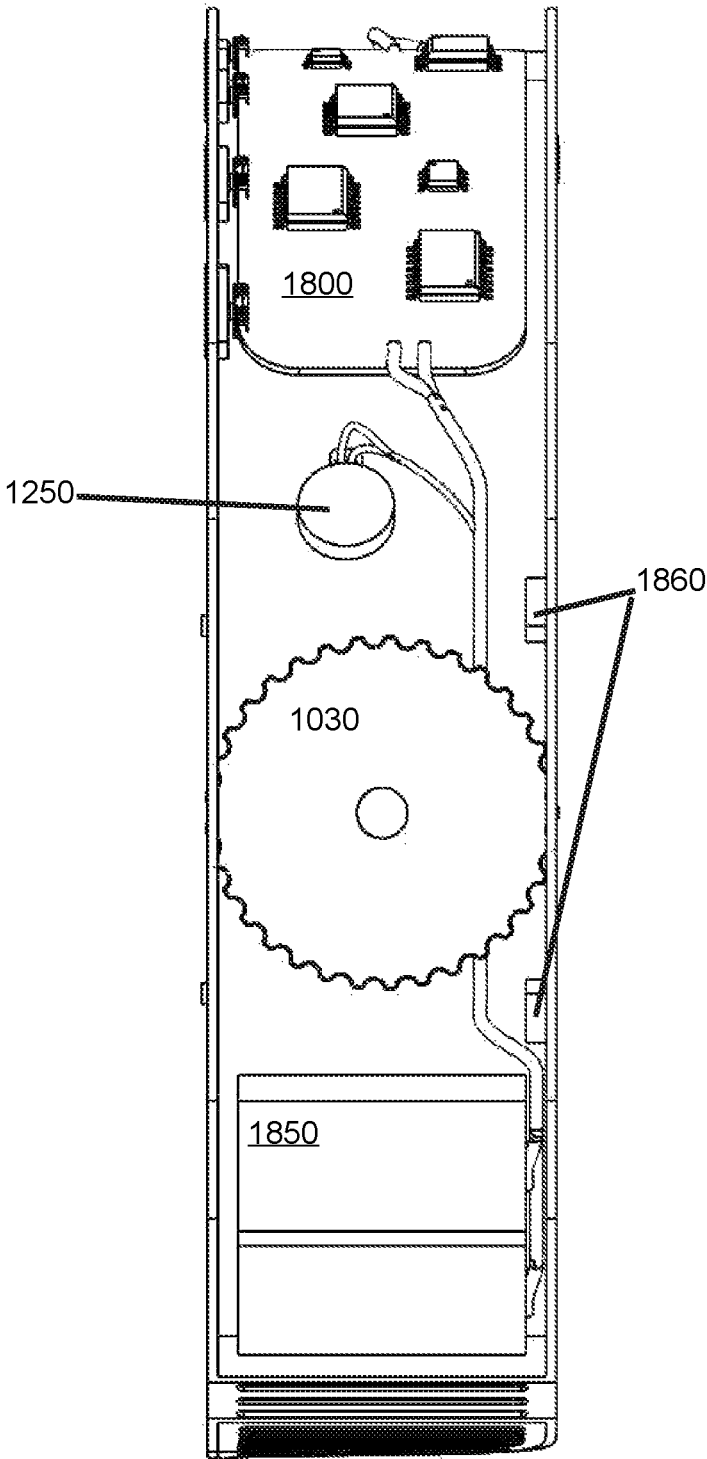

FIG. 24

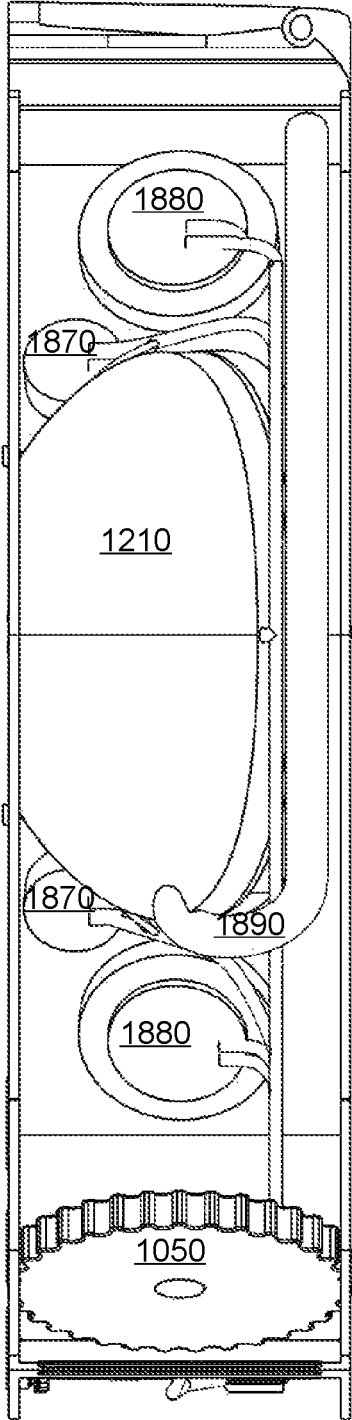

FIG. 25

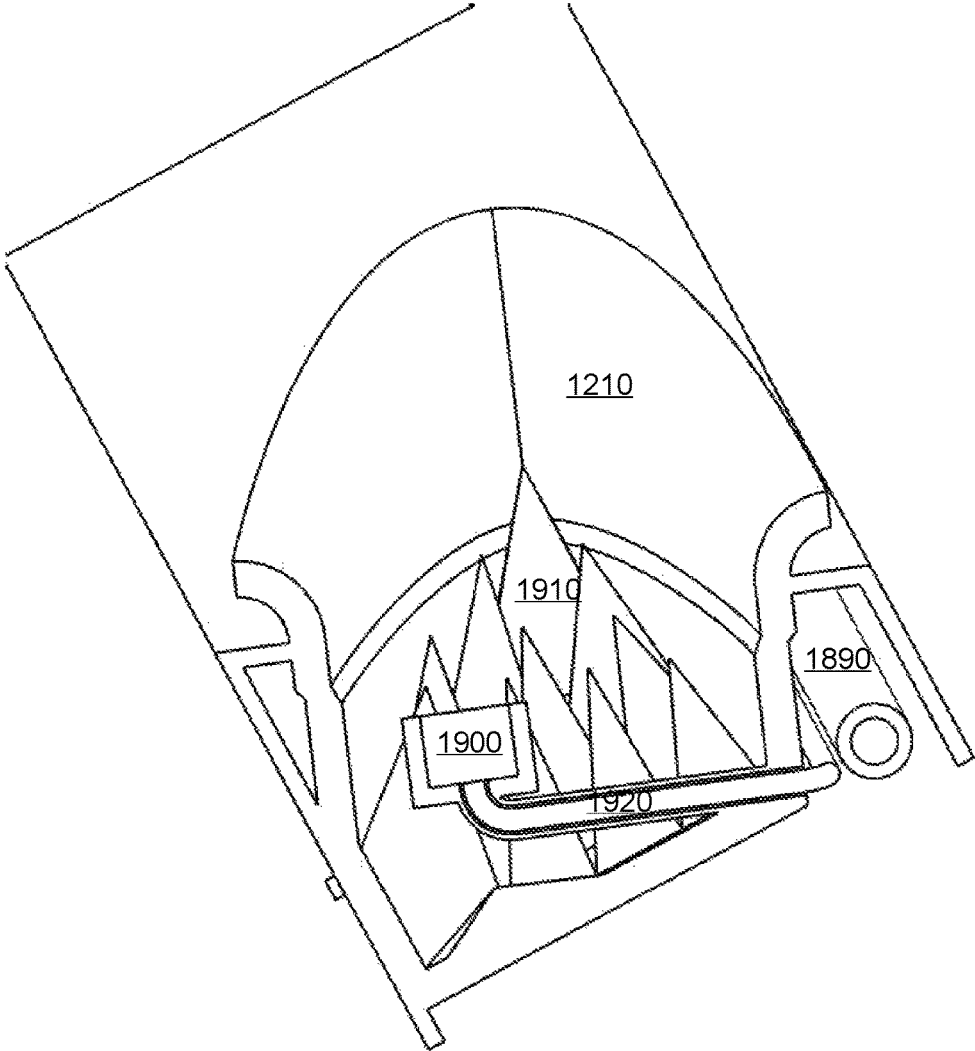

FIG. 26

ANTI-NOISE CANCELING HEADSET AND RELATED METHODS**CROSS-REFERENCE TO RELATED APPLICATIONS**

This application is a continuation-in-part (“CIP”) of U.S. patent application Ser. No. 13/979,265 (filed Dec. 22, 2015) for “Ergonomic anechoic anti-noise canceling chamber for use with a communication device and related methods.”

U.S. patent application Ser. No. 13/979,265 (filed Dec. 22, 2015) is a CIP of U.S. patent application Ser. No. 14/943,856 (filed Nov. 17, 2015), Ser. No. 14/740,129 (filed Jun. 15, 2015), and Ser. No. 14/577,839 (filed Dec. 19, 2014).

U.S. patent application Ser. No. 14/943,856 (filed Nov. 17, 2015) is a CIP of U.S. patent application Ser. No. 14/740,129 (filed Jun. 15, 2015) and Ser. No. 14/577,839 (filed Dec. 19, 2014).

U.S. patent application Ser. No. 14/740,129 (filed Jun. 15, 2015) is a CIP of U.S. patent application Ser. No. 14/577,839 (filed Dec. 19, 2014).

This application is also a CIP of U.S. patent application Ser. No. 14/577,839 (filed Dec. 19, 2014) for “Ergonomic tubular anechoic chambers for use with a communication device and related methods.”

U.S. patent application Ser. No. 14/577,839 is a CIP of U.S. patent application Ser. No. 14/280,523 (filed May 16, 2016) and claims the benefit of U.S. Prov. Pat. App. Ser. Nos. 61/949,239 (filed Mar. 7, 2014), 61/949,234 (filed Mar. 6, 2014), and 61/941,306 (filed Feb. 18, 2014).

U.S. patent application Ser. No. 14/280,523 (filed May 16, 2016) is now U.S. Pat. No. 8,948,411 and claims the benefit of U.S. Prov. Pat. App. Ser. Nos. 61/949,239 (filed Mar. 7, 2014), 61/949,234 (filed Mar. 6, 2014), and 61/941,306 (filed Feb. 18, 2014).

All of the documents reference in this section of “CROSS-REFERENCE TO RELATED APPLICATIONS” are hereby incorporated by reference.

STATEMENT REGARDING FEDERALLY SPONSORED RESEARCH OR DEVELOPMENT

Not applicable.

THE NAMES OF THE PARTIES TO A JOINT RESEARCH AGREEMENT

Not applicable.

REFERENCE TO AN APPENDIX SUBMITTED ON A COMPACT DISC AND AN INCORPORATED BY REFERENCE OF THE MATERIAL ON THE COMPACT DISC

Not applicable.

STATEMENT REGARDING PRIOR DISCLOSURES BY THE INVENTOR OR A JOINT INVENTOR

Reserved for a later date, if necessary.

BACKGROUND OF THE INVENTION**Field of Invention**

The disclosed subject matter is in the field of communication headsets. More specifically, the subject matter of this paper is in the field of communication headsets that conceal sounds made by the wearer. This paper may also disclose headset structures that are ergonomical or otherwise comfortable to the wearer. The subject matter of this written description is further in the field of devices for containing, absorbing and directing noise from a sound source while deflecting, absorbing and reflecting ambient noise. The subject matter of this disclosure is also in the field of systems and methods for maintaining privacy or avoiding public disruption during use of a communication device such as a telephone, mobile phone, two-way radio, and the like.

Background of the Invention

Mobile and fixed line communication devices (“communication devices”), such as cellular phones, two-way radios, or home phones, have become ubiquitous. In fact, some reports show telephone use by eighty seven percent of the global population. The commonality of these devices has resulted in their public use within the local vicinity of others. Conventional communication devices are not always suitable for public use. First, use of a conventional communication device in public often requires the user to expose the private details of a communication to others within the local vicinity. Even when a user retreats to a secluded location, the communications are subject to eavesdropping (e.g., by parabolic microphone, binoculars for lip reading, laser sound pick-up devices, and other distance eavesdropping devices). Subjecting the details of a secret or private communication to others is particularly concerning when such details involve matters of national security (e.g., details concerning FBI, CIA, diplomats, fire station, police, or military matters). Second, ambient noises in public areas can frequently disrupt a communication. For instance, ambient noise can frequently make it difficult for the user of the communication device to receive clear communications on the communication devices or to speak understandable commands to a device’s computer assistant employing voice recognizing software (e.g., SIRI® as utilized by the iPhone®). Thus, a need exists for apparatus and related methods for maintaining the privacy and clarity of communications over communication devices while avoiding the disturbance of others in the vicinity.

In view of the foregoing, many have proposed apparatus for enhancing privacy and clarity of communication devices while avoiding the disturbance of others nearby. These proposed apparatus involve covering the mouth or ear with a communication device so that a chamber is created over the mouth or ear in an attempt to confine the communicative sounds while blocking ambient noise. For instance, U.S. Pat. No. 7,564,968, U.S. Pub. App. No. 2011/0136535, U.S. Pat. No. 7,197,140, U.S. Pat. No. 8,778,062, and U.S. Pat. No. 7,515,708 disclose apparatus that are positioned over or in front of a mouth. Although capable of limited muffling of communicative sounds produced by the user of a communication device, these devices are not capable of capturing all of the communicative sounds of a device user that would otherwise be intelligible to those in the nearby vicinity. While some of these devices are capable of blocking small amounts of the direct field of communicative sounds, they are frequently inadequate for containing the more intense reverberant fields of the human speech sounds, for example, the reverberant fields of a male voice can be as low as eighty Megahertz (MHz). This functional inadequacy is the result

of two factors. First, the materials (or lack thereof) employed are not capable of absorbing enough of the communicative sound to render the communication unintelligible to eavesdroppers. Second, the chambers are not air-tight (particularly at any interface between the apparatus and the user's face (specifically, the ear and mouth)). When a chamber and related parts of the device are not air-tight, the direct or reverberant fields of the near-field (sounds in close proximity to the sound source) communicative sound (which is an acoustic sound wave through air) can leak out from the chamber before being totally absorbed by the chamber walls. Even when such apparatus initially form a seal around the mouth of a user, these seals can be upset by either (1) the sound air pressure or acoustic particle velocity of the communicative sound's near field sound energy (which are much more extreme than direct or reverberant fields) or (2) misalignment of the mouth and chamber near the upper and lower lips (i.e., the menton-subnasale length, bitragoin-subnasale arc area, and bitragoin-menton arc area) during movements of a user's face during normal speech. Misalignment along the menton-subnasale length, bitragoin-subnasale arc area, and bitragoin-menton arc area is particularly problematic when an apparatus must simultaneously provide mouth and ear coverings during use because these devices allow the ear coverings to operate despite misalignment along the menton-subnasale length area, bitragoin-subnasale arc area, or bitragoin-menton arc during movements of a user's face whereby a user may not even realize that sound from a private communication is being released. Even the slightest release of sound can be concerning during extremely sensitive communications over a communication device, for instance, during doctor-patient communications, lawyer-client communications, stockbroker-investor communications, interfamily communications, or communications involving national security. Furthermore, these devices are not substantially available for blocking ambient noise and thus clarity of communication using these devices can be compromised.

Other apparatus for enhancing privacy or clarity of communication involve a user facemask for creating a chamber over the mouth of a user. See, e.g., US Pub. Pat. No. 2007/0127659, U.S. Pat. No. 8,234,944, U.S. Pat. No. 7,783,034, and CN Pat. No. 2262732. However, these types of apparatus suffer from the drawbacks mentioned above, with the additional problem of being attention calling. Frequently, participants of a private communication, like national security agency members, do not want additional attention drawn to them by their communication device during sensitive telephone communications. Additionally: none of these facemask apparatus allow the user to breathe freely while being used without taking the device away from their face; none of the prior art have a controlled direction of airflow with sound energy to exit out the device in a controlled manner, with the users air from speech passing across a microphone without the intake air passing by the microphone so no acoustic interference will occur with the microphone; and none of the prior art use materials that are technically able to absorb the low base frequencies i.e. modelling clay that does not dry out and remains malleable.

SUMMARY OF THE INVENTION

In view of the foregoing, it is an object of this disclosure to describe an apparatus for maintaining the privacy and clarity of communications over devices and sounds of musical instruments or voices. It is another objective to disclose such apparatus without the drawbacks identified

above. Disclosed, in general, are devices that provide a substantially air-tight chamber over a sound source while absorbing relatively all frequency fields of speech, singing, or instrument sounds from the sound source. In some embodiments, active noise control or active noise cancellation means ("ANC means") are provided to the device. Said means include a sound source for the addition of sound specifically designed to cancel noise within the anechoic chamber. Although it may be difficult to accept that adding two sounds 180 degrees out of phase can result in zero sound, it is important to remember that sound is a compression wave that compresses to an amount greater than normal air pressure. There are so many frequencies in sound, it is impossible to cancel them all out. A preferred embodiment of the disclosed system features an electronic system that selects a narrow band of frequencies to cancel them using a DSP (Digital Signal Processor). Suitably, the DSP does not result in one hundred percent (100%) cancellation of noise, but other sound absorption from the anechoic chamber or other components can block sounds at other frequencies.

In general, the devices feature: anechoic chambers that are configured to receive a sound source in an air-tight manner; ANC means (e.g., a DSP) for reducing unwanted sound by the addition of a second sound within said anechoic chambers; and anechoic channels that are in fluid communication with the ambient environment. Preferably, the anechoic channels allows air flow out of the anechoic chambers. Suitably, the anechoic chambers are adapted to capture air containing sound energy generated by the sound source (e.g., human voice), and distribute the air about internal anechoic acoustical surface areas on the inside of the chambers, wherein the internal surface areas are maximized and sufficiently large to dampen or otherwise absorb the sound energy. The amount of sound energy absorbed by the anechoic chambers can be reduced via the presence of an ANC means (like an antiphase/anti-noise speaker) for reducing the sound energy in the captured air by providing the addition of a second out of phase sound to within the anechoic chamber. Placement of a user's face inside the sealed area also acts to absorb sound waves in the anechoic chamber. Preferably, the deenergized air is directed from the near-field anechoic sound chamber through a Helmholtz resonator or other tubular anechoic channel extending therefrom to the ambient atmosphere to further dampen or absorb and contain the sound energy. Once sound energy is absorbed from the anechoic chambers, the air preferably exhausts from the apparatus substantially free of any sound energy. This feature permits a user to pass fresh air into the chamber via an air intake mechanism without pressure buildup as the user's sound containing air is vented out of the anechoic channel or Helmholtz resonator. The Helmholtz resonator design preferably "tunes" the exhaust air so the voice energy sound that leaves is less than 100 hz (i.e., just below the hearing threshold). In one configuration, the outer wall of the apparatus is configured to reflect ambient sounds. In another embodiment, the apparatus features an ear sealed chamber to keep ambient sounds out of a user's ear.

It is yet a further objective to disclose devices that provide an air-tight chamber over the mouth and ear of a user while absorbing all megahertz frequency fields of communicative sounds by male and female speakers. In one embodiment, the device is defined by: an anechoic chamber with a mouth opening plus an anechoic channel for dampening acoustics about a receiver portion of a communication device; an antiphase/anti-noise speaker disposed within the anechoic chamber; and an ear chamber with an ear opening dampen-

5

ing acoustics about a microphone of a communication device. In a preferred embodiment, the device features electronics software on a printed circuit board (PCB), which measures the sound of a user's voice in decibels (dB) via a microphone and creates an antiphase noise to cancel the sound of the user's voice at substantially the exact same volume (dB) level as the speaker's voice in substantially real-time (the best as the software can interpret the speech sounds and create antiphase sound waves). In a preferred embodiment, the ear and anechoic chambers are configured for placement so that the device lies along the mentocervical angle, mentocervical angle length, menton-subnasale length, bitragoin-subnasale arc, or bitragoin-menton arc of a user at a range of nineteen to twenty three degrees. Other embodiments may not incorporate these angles. In use, a mouth may be placed in the mouth opening to create a substantially air-tight seal and position the mouth so that the acoustics of a communicative sound from the mouth are directed toward the receiver portion of the communication device within the anechoic chamber. By allowing the specific ergonomic design of the mouth seal to push easily into the soft tissue of a user's face around the user's teeth, a substantially air-tight seal is created that does not hinder the user's ideal pronunciation and intonation of verbs, adjectives, pronouns and other words. In a preferred embodiment, air from the user's breath during speech is directed through the anechoic channel for improved acoustic absorption and microphone sound pick-up. The result is voice communication being contained within the anechoic chamber of the device for maintaining privacy of the phone conversation.

Preferably, the apparatus is configured to fit securely over the ear and mouth of a user, without breaking the air tight seal between the mouth opening and mouth of a user and the seal between the ear opening and the ear of a user. Suitably, this is accomplished via positioning the apparatus at a metocervical angle in a range of fifteen and twenty five degrees relative to the face of a user. Other embodiments need not incorporate these angles. A preferable metocervical angle position for the apparatus is about nineteen degrees for female users and about twenty three degrees for male users. These metocervical angle positions result in the appropriate ear to mouth engagement at an eighty-eighth percentile relationship for both of the bitragion sub-nasale arc and the bitragion-menton arc anthropometric measurements. This insures even/equal user pressure around the entire menton subnasale area (i.e., direct contact area of the entire perimeter of the product's face sound seal) and the center of the ear.

It is yet a further objective of the invention to disclose a device that works in conjunction with a phone and provides a substantially air-tight chamber over a sound source while absorbing relatively all frequency fields of speech from the sound source. In an alternative embodiment, the phone features: hollow chambers that reduce noise by allowing expanding sound waves to be decelerated and cooled, allowing the sound waves to be greatly reduced in velocity, which produces less noise signature.

Finally, it is an object of the disclosure to describe a telephone handset that features an antiphase/anti-noise speaker within an anechoic chamber so that noises provided therein can be combated with antiphase noises. In some embodiments, the antiphase/anti-noise speaker can be a DSP. In some embodiments, the headset is designed to include passive and active noise cancellation of a user's voice. Suitably, the headset can be adjusted to fit an inclusive range of head dimensions comfortably, the headsets may

6

connect wirelessly to the user's phone to ensure cable free operation and communication.

Other objectives and desires may become apparent to one of skill in the art after reading the below disclosure and viewing the associated figures. Also, these and other embodiments will become apparent from the drawings.

BRIEF DESCRIPTION OF THE SEVERAL VIEWS OF THE DRAWINGS

Other objectives of the disclosure will become apparent to those skilled in the art once the invention has been shown and described. The manner in which these objectives and other desirable characteristics can be obtained is explained in the following description and attached figures in which:

FIG. 1 is a perspective view of an anechoic device;

FIG. 2 is a perspective view of the device of FIG. 1 with a blow-out depicting the sound reflecting surface contours of the device;

FIG. 3 is a cross section of an apparatus for ensuring the privacy and clarity of communications over communication devices;

FIG. 4 is a cross section of the shell of the device showing isolated anechoic chambers separate from the electric components;

FIG. 5 is a cross section of a side wall of an anechoic chamber;

FIG. 6 is an environmental view of the device;

FIG. 7 is a front view of another embodiment of a device;

FIG. 8 is a rear view of the device of FIG. 7;

FIG. 9 is a right-side view of the device of FIGS. 7 and 8;

FIG. 10 is a left-side view of the device of FIGS. 7 through 9;

FIG. 11 is a cross section of the device of FIGS. 7 through 10;

FIG. 12 is an illustration of the operations of the device of FIG. 7 through 11.

FIG. 13 is a front view of a headset;

FIG. 14 is a top view of a headset;

FIG. 15 is a top cross-section view of a headset;

FIG. 16 is an isometric, left view of a headset **1000** on a human head **2000**;

FIG. 17 is an isometric, left view of the headset **1000** of FIG. 16;

FIG. 18 is an isometric, right view of the headset **1000** of FIGS. 16 and 17 on the human head **2000** of FIG. 16;

FIG. 19 is an isometric, right view of the headset **1000** of FIGS. 16 through 18;

FIG. 20 is a top view of the headset **1000** of FIGS. 16 through 19;

FIG. 21 is a top view of the headset **1000** of FIGS. 16 through 20 in a folded configuration;

FIG. 22 is an internal right-side view of the headset **1000** of FIGS. 16 through 21;

FIG. 23A is an internal backside view of the headset **1000** of FIGS. 16 through 22;

FIG. 23B is a see-through internal backside view of the headset **1000** of FIGS. 16 through 22;

FIG. 24 is an internal back view of the headset **1000** of FIGS. 16 through 23B;

FIG. 25 is an internal front view of the headset **1000** of FIGS. 16 through 24; and,

FIG. 26 is a cross-section of a mouth portion of the headset **1000** of FIGS. 16 through 26.

It is to be noted, however, that the appended figures illustrate only typical embodiments of this invention and are

therefore not to be considered limiting of its scope, for the invention may admit to other equally effective embodiments that will be appreciated by those reasonably skilled in the relevant arts. Also, figures are not necessarily made to scale but are representative.

DETAILED DESCRIPTION OF PREFERRED EMBODIMENTS

Disclosed, in general, are devices that provide an air-tight chamber over a sound source while trapping, containing, absorbing, directing and deflecting all fields of sounds from the sound source (e.g., the mouth of a human or a woodwind instrument). In general, the devices feature: a specialized anechoic chamber that is configured to receive a sound source in an air-tight manner; and a specialized anechoic channel that is in fluid communication with the ambient atmosphere. Suitably, the anechoic chamber is adapted to capture air containing sound energy generated by the sound source, and distribute the air about an internal surface area on the inside of the chamber, wherein the internal surface area is sufficiently large to dampen or otherwise absorb the sounds energy. Preferably, the air is directed from the anechoic chamber through an anechoic tubular channel extending therefrom to the ambient to further dampen or absorb the sound energy. In one configuration, the outer wall of the apparatus is configured to reflect ambient sounds. The more specific details of the preferred embodiment are disclosed in connection with the figures.

By allowing the specific ergonomic design of the mouth seal to push easily into the soft tissue of a user's face around the user's teeth, a substantially air-tight seal is created that does not hinder the user's ideal pronunciation and intonation of verbs adjectives, pronouns and other words easily without stress on the areas of the lips used for pronunciation. Preferably, the apparatus is configured to fit securely over the ear and mouth of a user, without breaking the air tight seal between the mouth opening and mouth of a user and the seal between the ear opening and the ear of a user. Suitably, this is accomplished via positioning the apparatus at a metocervical angle in a range of fifteen and twenty five degrees relative to the face of a user. A preferable mentocervical angle position for the apparatus is about nineteen degrees for female users and about twenty three degrees for male users. These metocervical angle positions result in the appropriate ear to mouth engagement at an eighty-eighth percentile relationship for both of the bitragion sub-nasale arc and the bitragion-menton arc measurements. This insures even/equal user pressure around the entire menton subnasale area (i.e., direct contact area of the entire perimeter of the product's face sound seal) and the center of the ear.

FIG. 1 is a perspective view of an apparatus 1000 for maintaining the privacy and clarity of communications made over a communication device. As shown, the apparatus 1000 is generally in the shape of a telephone handset and defined by: (1) an anechoic chamber 1100 with a mouth opening 1110 for engaging a mouth of a user; (2) a handle 1200; and, (3) an ear chamber 1300 with an ear opening 1310 for engaging the ear of a user.

As shown in FIG. 1, the handle 1200 is generally curved wherein: an anechoic chamber 1100 is generally positioned at the lower end of the handle 1200; and the ear chamber 1300 is positioned at an upper end of the handle. Both the anechoic chamber 1100 and the ear chamber 1300 generally define basins at either end of the handle 1000. The specifically designed anechoic chamber 1100 preferably features

contours 1130 on its inner walls and cushioning 1140 around the lip of the mouth opening. Similarly, the ear chamber features cushioning 1330 around the lip of the ear opening 1310. Finally, the handle 1200 is configured with a curve so that it can be gripped by the hand of a user while the ear and anechoic chambers are simultaneously positioned over the ear and mouth. In a preferred embodiment, the handle has a curvature and shape of a banana fruit for the ergonomic use and comfort of a user. Although not shown, the handle 1200 may further feature grips to assist users with arthritis afflictions in holding the apparatus 1000.

As discussed in greater detail below, the apparatus 1000 is designed to receive and transmit telephone communications from and to a communication device (e.g., wirelessly via Bluetooth® type technology) or wired communication device (e.g., landline phone) and generally be operated in the manner of a telephone handset. For this reason, FIG. 1 depicts an air inlet 1120 within the anechoic chamber 1100. As discussed in greater detail below, the vent 1120 suitably features a triple layer air seal design that blocks ambient sounds from entering the anechoic chambers during a user's speech and that easily flexes under a negative pressure within the chamber 1100 to allow sufficient air into the chamber 1100 during speech. In other words, the vent 1120 makes it so the user does not have to pull away from the apparatus 1000 to breathe during use. Also depicted are (a) phone controls 1210 (e.g., volume and accept or decline buttons, hold button, or mute speaker button) on the handle 1200, power ports 1220 on the handle 1200, an audio port 1230 (e.g., for receiving a headphone jack), and speaker holes 1320 within the ear chamber 1300. In a preferred embodiment, the phone controls 1210 include a hold or mute button that will allow the user essentially turn off the phone when not engaged against the user's face to shield the listening party from the ambient noise or discussion of the user.

FIG. 2 is a recreation of the perspective view of the apparatus 1000 FIG. 1, with an additional blow-out view to illustrate the external surface of the apparatus 1000. As shown in the blow-out view, the external surface of the apparatus is defined by a hex-skin or a plurality of hexagonal tiles positioned in an array over the surface of the apparatus 1000. In a preferred embodiment, each hexagon defines a plane or face for reflecting ambient sound energy, wherein each plane or face is angled on a lightly different angle relative to the plane of any adjacent hexagon within the skin. This angular offset from polygonal shapes results in ambient sound deflection to maintain the quality of sounds within the apparatus. Suitably, this angular offset weakens the ambient sound's intensity by not allowing sound energy to focus on a specific area on the surface of the outside of the anechoic chamber 1100. In a preferred embodiment, the surface of each hexagon is contoured to further disrupt ambient sounds via minimal absorption and deflection so that large focused sound energy cannot enter the anechoic chamber. Other polygonal patterns may be integrated.

FIGS. 3 and 4 are cross-sections of the apparatus 1000 depicted in FIG. 1. These cross-sections are intended to illustrate the interior workings of the claimed device. Specifically, FIG. 3 illustrates the inner workings of the sound trapping, containing, absorbing, directing and deflecting components of the apparatus 1000 and FIG. 4 illustrates the electrical components for telephonic communications. Referring to both FIGS. 3 and 4, the phone electronics are, (apart from a microphone 1270) disposed within the acoustic chamber, and preferably isolated from sound absorbing components to ensure the sound components create a sub-

stantially or completely air-tight environment. As noted below in greater detail, the vent **1120** (FIG. 3) is positioned relative to the microphone **1270** (FIG. 4) so that flowing air upon fresh air-intake does not cause interference with the microphone **1270**. Additionally, the vent **1120** should be flush with the external surface and positioned in the middle of the apparatus **1000** so that, when facing sound, the vent does not provide energy that may be reflected.

Referring first to FIG. 1 and FIG. 3, sound may be captured and/or absorbed or directed from the flow of air caused by speech during use of the apparatus **1000**. In a preferred embodiment, sound energy **1** is captured or absorbed via the anechoic chamber **1100** and the anechoic channel **1250** disposed within the handle **1200**. Suitably, the anechoic chamber **1100** is adapted, to capture air **2** containing sound energy generated by a sound source (not shown), and distribute the air **2** over the inner surface of the chamber **1100** and through the anechoic channel **1250** (i.e., the channel **1250** provides fluid communication between the anechoic chamber **1100** and the ambient). The amount of air **2** being passed over the vocal cords is directly proportionate to voice sound volume.

Still referring to the same figures, the anechoic chamber **1100** features a vent **1120**. The vent **1120** is provided so that (a) air may be supplied to the user without disengaging the device from the users face mouth and ear whereby a substantially air-tight seal may remain between the anechoic chamber **1100** and a user's face. The vent **1120** opens under negative pressure within the chamber. The vent **1120** closes under the positive pressure caused by a sound source within the chamber **1100**. This inlet preferably allows air **2** to pass into the anechoic chamber **1100**. In a preferred embodiment, the inlet is defined by a vent **1120** with triple rubber flex valves in a naturally closed position. The triple valve provides ambient sound insulation/shielding during speech. The rubber flex valves easily open when a breath of fresh air is needed to breathe while speaking. As shown in FIG. 3 and FIG. 1, the anechoic chamber **1100** features contours **1130** for increasing the surface area of its internal sidewalls. Preferably, these peak contours **1130** are a specific shape to enhance the absorption of low base megahertz frequencies. Further surface area is provided via placing small holes or pores in the Contours **1130**. In the depicted embodiment those contours **1130** are defined by wedges or ridges. Suitably, similar pored contours **1251** may be provided to the inner walls of the anechoic channel **1250**. As shown, the contours **1251** cooperate to guide energized air (energized with near field sound energy that was not absorbed or contained in the anechoic chamber **1100**) over its surface area and around corners to physically make the air lose sound wave energy. In a preferred embodiment, the anechoic chamber **1100** and channel **1250** is provided with an air vent **1252** through the handle **1200** so that air that has been de-energized of sound energy may be exhausted to the ambient atmosphere. As shown, the exhausted air **2** from the vent **1252** is directed away from the ear chamber **1300** so that if any sound energy remains in the air, the remnant energy will be directed away from the ear chamber **1300** (FIG. 1) and its speaker.

Still referring to FIGS. 1 and 3, the sidewalls of the anechoic chamber **1100** and anechoic channel **1250** are configured to trap, contain, absorb, direct, and deflect sound energy from air that contacts its surface area. For this purpose, the sidewalls of the anechoic chamber **1100** and channel **1250**, the sidewalls are constructed of dense open cell acoustic foam for maximum energy absorption and dissipation. When air contains large amounts of sound

energy, some of that energy will inevitably propagate through materials designed to absorb the energy and potentially be released to the ambient atmosphere. In view of this fact, the sidewalls preferably feature layers with various acoustical properties (including energy densities) for further sound absorption and reflection of sound energy back toward the inside of the anechoic chamber **1200** and the user's face. These layers are depicted in FIG. 5, which is a cross section of a typical sidewall.

Referring to FIGS. 5 and 3, the inner walls of the anechoic chamber **1100** and the anechoic channel **1250** are suitably constructed in layers. As shown in FIG. 5: a first layer **1252** may be defined by an anti-microbial sound absorbent coating to maximize bass dampening while not allowing the surfaces in contact with the users saliva to become ridden with bacteria; a second layer **1253** comprised of dense open cell acoustic foam defining the pored contours **1130** and **1251** of the chamber **1100** and channel **1250**; a third layer **1254** for defined by a composite (e.g., modeling clay that will not shrink or dry always staying permeable) or foil/metal (e.g., aluminum foil or light gauge sheet metal) for absorbing, deflecting and reflecting energy back to within the anechoic chamber and thru to the channel up to the exhaust; a fourth layer **1255** of dense open cell acoustic foam; a fifth layer **1256** of a composite or foil/metal or clay for absorbing and or reflecting energy; a sixth layer **1257** of large, open cell plastic; and the outer shell of the apparatus **1000**. As shown in FIGS. 3 and 5, sound energy **5** is absorbed by the second layer **1253** and, if not, the energy **6** is reflected by the third layer **1254**. The second and third layers are important to function because if energy is not adsorbed by the second layer **1253** it is reflected by the third layer **1254**. The configuration of functional specific layers of coatings, open cell foam, sheet metal, modeling clay, rubber layers is specifically designed to absorb, contain, reflect and direct the different ranges of frequencies/wavelengths of the sound waves from and male and female speaking, singing and playing a musical instrument, and therefore the combination of these layers, or sets of layers (example: modeling clay backed by thin metal), work to maximize all sound energy absorption and prevent the sound energy from escaping the device.

Referring now to FIG. 4, the upper portion of the handle **1200** features a housing **1260** for retaining the electronics that enable the apparatus to be used in the manner of a telephone handset. This housing **1260** further allows for sound vibration isolation from the anechoic chambers **1100** and sub assembly for manufacturing. This configuration allows the anechoic chamber **1100** to be easily assembled in a substantially air tight manner, which may be important to operation of the device. The electronic separation is also needed to direct and expel the electronic heat from the device. As shown, the housing **1260** retains a battery **1261**, a mother circuit board **1262** that is electrically coupled to the phone controls **1210** (including volume controls, on/off controls, and hold microphone button controls), a speaker **1263**, a microphone **1270** that is specifically designed to function in a positive air pressure environment, and a receiver/transmitter **1264** (e.g., Bluetooth®) (which may be coupled to the mother circuit board **1262** for receiving and transmitting communications to and from a device (e.g., cell phone, two way radio, or home phone). To vent the naturally occurring build-up of heat from electronic operations, the housing **1260** is outfitted with a vent **1280** for venting heat from the housing **1260**. This isolated vent **1280** also allows the devices audio speaker to naturally flex its speaker membrane for clear sound amplification. These phone elec-

11

tronics are configured to operate in the manner of a Bluetooth® or other wireless headset for mobile, home, or office communication devices. The jack 1230 is preferably a 3.5 mm industry standard headphone jack so the device can be wired (linked) to a cell phone without bluetooth. In such configurations the blue tooth components will either be off or not located in the device. As shown, the microphone 1270 is positioned within the anechoic chamber from the housing 1260 so that no saliva generally comes in contact with the users "salvia spray" while speaking. The microphone 1270 is also positioned so air from the intake will not cause "noise" air flow interference from incoming air when the user breathes. Suitably, the microphone 1270 is configured for use within a pressurized chamber and with an air tight seal between the anechoic chamber 1100 and the housing 1260. In other words, the microphone 1270 is specifically designed to function in a positive air pressure environment. The microphone 1270 may preferably be passed through a housing 1260 via opening 1291 (see FIG. 3). Again, this specific position allows for isolation from the majority of the sound vibrations and also to aid in sub manufacturing assemblies. Finally, weights 1271 and 1272 may be positioned at the upper and lower portions of the apparatus 1000 for balance.

As alluded to above, the apparatus 1000 is designed to be operated in the manner of a telephone handset. FIG. 6 shows an environmental view of the apparatus 1000 in operation. As shown, the apparatus 1000 is operated via placing (1) the mouth opening 1110 securely over the mouth of a user so that the cushioning 1140 or flexible rubber seal of the device 1000 is firmly and comfortably positioned around the mouth of the user and (2) the ear opening 1310 over the ear of a user so that the cushioning 1330 is firmly positioned around or over the ear of a user. Suitably, the anechoic chamber cushioning 1140 or flexible rubber seal is configured to act as an air-tight gasket between the interface of the mouth and anechoic chamber 1100. In one embodiment, the cushioning may be removable, disposable, and replaceable to avoid build-up of dirt, bacteria and other substances that may accumulate during use. FIG. 13 illustrates the positioning of the device 1000 over the mouth. Suitably, the mouth opening is generally mouth shaped and curved so that it may be pressed around the mouth of a user and into the soft tissue 5000 (the area indicated by dashed lines) of the face. In a preferred embodiment, the mouth opening must engage the soft tissue of the face so that the mouth piece pushes softly into the face without interfering with the lips so the user has no difficulties speaking and singing normally. This engagement creates a substantially air-tight seal around the mouth of a user and allows the ear chamber 1300 to be properly positioned over the ear. The ear chamber 1300 cushioning 1330 is configured to act as a gasket between the interface of the ear and ear chamber 1200.

Preferably, the apparatus is configured to fit securely over the ear and mouth of a user, without breaking the air tight seal between the mouth opening 1110 and mouth of a user and the seal between the ear opening 1310 and the ear of a user. Suitably, this is accomplished via positioning the apparatus at a metocervical angle in a range of fifteen and twenty five degrees relative to the face of a user. Other embodiments need not incorporate these angles. A preferable metocervical angle position for the apparatus is about nineteen degrees for female users and about twenty three degrees for male users. These metocervical angle positions result in the appropriate ear to mouth engagement at an eighty-eighth percentile relationship for both of the bitragoin sub-nasal arc and the bitragion-menton arc anthropometric

12

measurements. This insures even/equal user pressure around the entire menton subnasale area (i.e., direct contact area of the entire perimeter of the product's face sound seal) and the center of the ear.

FIG. 7 is a front view of another embodiment of a device 1000. FIG. 8 is a rear view of the device 1000. FIG. 9 is a right-side view of the device 1000. FIG. 10 is a left-side view of the device 1000. This device 1000 differs from embodiments of the device shown in FIGS. 1 through 6 in two meaningful ways. First, the device 1000 of FIGS. 7 through 10 features an improved notification light 2000 to alert a user to the status of the device 1000. Second, the device 1000 of FIGS. 23 through 26 features active noise control or active noise cancellation means ("ANC means") 1270 inside of the device 1000. Said means 1270 includes a sound source (like an antiphase/anti-noise speaker) for the addition of sound specifically designed to cancel noise presented within the anechoic chamber 1100.

FIG. 11 is a cross section of the device of FIGS. 7 through 10. FIG. 11 shows the internal placement of the ANC means 1270 and the light 2000 within the device 1000. As shown, the ANC means is electrically coupled to the coupled to the printed circuit board of the device 1000 so that it is positioned within the anechoic chamber 1100. The light 2000 features a light source and is also electrically coupled to the PCB of the device 1000.

FIG. 12 is an illustration of the operations of the device 1000. As shown, ANC means 1270 are provided to the device 1000. Said means 1270 include a sound source for the addition of sound specifically designed to cancel noise outside of the anechoic chamber. Preferably, the ANC means 1270 reduces unwanted sound by the addition of a second sound within said anechoic chamber 1100. Suitably, the anechoic chambers are adapted to capture air containing sound energy generated by the sound source (e.g., human voice), and distribute the air about internal anechoic acoustical surface areas on the inside of the chambers, wherein the internal surface areas are maximized and sufficiently large to dampen or otherwise absorb the sound energy. The amount of sound energy absorbed by the anechoic chambers can be reduced via the presence of an ANC means (like an antiphase/anti-noise speaker) for reducing the sound energy in the captured air by providing the addition of a second sound to within the anechoic chamber. Placement of a user's face inside the sealed area also acts to absorb sound waves in the anechoic chamber. In a preferred embodiment, the device features electronics software on a printed circuit board (PCB) which measures the sound of a user's voice via a microphone and creates an antiphase noise to cancel the sound of the user's voice in substantially real-time (the best as the software can interpret the speech sounds and create antiphase sound waves). In a preferred embodiment, the ear and anechoic chambers are configured for placement so that the device lies along the mentocervical angle, mentocervical angle length, menton-subnasale length, bitragoin-subnasale arc, or bitragoin-menton arc of a user at a range of nineteen to twenty three degrees. Other embodiments may not incorporate these angles. In use, a mouth may be placed in the mouth opening to create a substantially air-tight seal and position the mouth so that the acoustics of a communicative sound from the mouth are directed toward the receiver portion of the communication device within the anechoic chamber. By allowing the specific ergonomic design of the mouth seal to push easily into the soft tissue of a user's face around the user's teeth, a substantially air-tight seal is created that does not hinder the user's ideal pronunciation and intonation of verbs adjectives, pronouns and other

13

words easily without stress on the areas of the lips used for pronunciation. In a preferred embodiment, air from the user's breath during speech is directed through the anechoic channel for improved acoustic absorption and microphone sound pick-up. The result is voice communication being contained within the anechoic chamber of the device for maintaining privacy of the phone conversation.

Further disclosed, in general, are devices that provide a substantially active noise canceling area over a sound source by causing disruptive interference to all frequency fields of speech sounds from the sound source. In some embodiments, active noise control or active noise cancellation means ("ANC means") are provided to the device. Said means include one or more active noise canceling speakers for the addition of sound specifically designed to cancel noise from the speech sound source. In general, the devices feature: ANC means that are configured to destructively interfere with a sound source by the addition of an antiphase sound in an area around the sound source; a support arm for supporting the ANC means proximate to the sound source. Suitably, the ANC means are adapted to destructively interfere with sound energy generated by the sound source (e.g., human voice), and substantially cancel the sound energy. The amount of sound energy can be reduced via the presence of an ANC means (like an antiphase/anti-noise speaker) for reducing the sound energy. In one configuration, the apparatus features an ear sealed chamber coupled to the support arm and positioned over a user's ear to keep ambient sounds out of a user's ear.

The disclosed devices may provide a substantially active noise canceling area over a sound source by causing disruptive interference to all megahertz frequency fields of communicative sounds by male and female speakers. In one embodiment, the device is defined by: a plurality of ANC means antiphase/anti-noise speakers) disposed about a receiver portion of a communication device; a support arm for the ANC means and receiver portion; and an ear chamber with an ear opening dampening acoustics about a microphone of a communication device. In a preferred embodiment, the device features electronics software on a printed circuit board (PCB), which measures the sound of a user's voice via a microphone and creates an antiphase noise to cancel the sound of the user's voice in substantially real-time (the best as the software can interpret the speech sounds and create antiphase sound waves). In a preferred embodiment, the ear and mouthpiece are configured for placement so that the device lies along the mentocervical angle, mentocervical angle length, mentonsubnasale length, bitragoin-subnasale arc, or bitragoin-menton arc of a user at a range of nineteen 5 to twenty three degrees. Other embodiments may not incorporate these angles. In use, a mouth may be placed adjacent to the ANC means and receiver portion to position the components in front of the mouth so that the acoustics of a communicative sound from the mouth are directed toward the receiver portion of the communication device. In a preferred embodiment, air from the user's breath during speech is directed through anti-phase noise created by the ANC means after interaction with the receiver portion of the device for improved acoustic absorption and microphone sound pick-up. The result is voice communication being noise canceled after pickup by the receiver for maintaining privacy of the phone conversation.

FIG. 12 is also an illustration of the operations of the device 1000. As shown, ANC means 1270 are provided to the device 1000 around the mouthpiece 1200. Said means 1270 include a sound source for the addition of sound specifically designed to cancel noise outside of the anechoic

14

chamber. Preferably, the ANC means 1270 reduces unwanted sound by the addition of antiphase sound around the mouth of a user. Suitably, the mouth piece 1200 is adapted to detect air containing sound energy generated by the sound source (e.g., human voice), and distribute the antiphase sounds to destructively interfere or otherwise cancel the sound energy. In a preferred embodiment, the device features electronics software on a printed circuit board (PCB) which measures the sound of a user's voice via a microphone and creates an antiphase noise to cancel the sound of the user's voice in substantially real-time (the best as the software can interpret the speech sounds and create antiphase sound waves). In a preferred embodiment, the ear and mouth pieces are configured for placement so that the device lies along the mentocervical angle, mentocervical angle length, menton-subnasale length, bitragoin-subnasale arc, or bitragoin-menton arc of a user at a range of nineteen to twenty three degrees.

FIG. 13 is a front and environmental view of another embodiment of a device 1000. FIG. 14 is a top and environmental view of the device 1000. FIG. 15 is a cross-section of the device 1000. As shown, the device 1000 of FIGS. 13 through 15 features active noise control or an active noise cancellation mouthpiece 1200, a support arm 1100, and an ear piece 1300. Suitably, the mouth piece 1200 features at least one ("ANC means") 1270 on its periphery and a microphone 1280 plus receiver 1281 directed toward a user's mouth (See FIG. 32). Said ANC means 1270 includes a sound source (like an antiphase/anti-noise speaker) for the addition of sound specifically designed 5 to cancel noise presented toward the receiver 1280. In operation, the mouthpiece picks-up voice sounds from the user via the microphone 1280 plus receiver 1281 and projects an active noise canceling area 4000 (shown in broken lines) around the user's mouth 3000 via projecting antiphase noise (shown as crisscrossing lines 3100) in all 10 directions from the ANC means 1270 to destructively interfere with any voice sounds produced from the user's mouth. In this manner, the antiphase sound waves operate as a soundwave "wall" in the area around the mouth and in a matching volume level to cancel sound energy from the sound source (i.e., the human voice). Suitably, once the anti-noise/anti phase speaker sound waves hit the user's face, the residual sound, not noise canceled, becomes absorbed by the user's face with the reverberant energy reflecting off at a highly diminished decibel level.

FIG. 15 is a cross section of the device of FIG. 14. FIG. 15 shows the internal placement of the ANC means 1270 and other components within the device 1000. The support arm 1100 features a housing 1260 for retaining the electronics that enable the apparatus to be used in the manner of a telephone headset. As shown, the ANC means is electrically coupled to the printed circuit board 1150 of the device 1000 that is positioned within the support arm 1100 of the device. The positioning of the electronics in the arm 1100 5 is convenient to direct and expel the electronic heat from the device. As shown, the arm 1100 retains a battery 1161, a mother circuit board 1150 that is electrically coupled to the phone controls 1110 (including volume controls, on/off controls, and hold microphone button controls), a speaker 1263, an ambient sensing 10 microphone 1265, a microphone 1280 that is specifically designed to function in a positive air pressure environment, and a receiver/transmitter 1281 (e.g., Bluetooth®) (which may be coupled to the mother circuit board 1150 for receiving and transmitting communications to and from a device (e.g., cell phone, two way radio, or home phone). These phone electronics are

15

configured to operate in the manner of a Bluetooth® or other wireless headset for mobile, home, or office communication devices. In such configurations the blue tooth components will either be off or not located in the device. The microphone **1280** is also positioned so air from the intake will not cause “noise” air flow interference from incoming air when the user breathes. Suitably, the microphone **1280** is specifically designed to function in a positive air pressure environment.

Yet another embodiment of this disclosure may be a telephone headset that features an antiphase/anti-noise speaker within an anechoic chamber so that noises provided therein can be combated with antiphase noises. In some embodiment, the antiphase/anti-noise speaker can be a DSP. In some embodiments, the headset is designed to include passive and active noise cancellation of a use’s voice. Suitably, the headset can be adjusted to fit an inclusive range of head dimensions comfortably, the headsets may connect wirelessly to the user’s phone to ensure cable free operation and communication.

FIG. **16** is an isometric, left view of a headset **1000** on a human head **2000**. FIG. **17** is an isometric, left view of the headset **1000** of FIG. **16**. FIG. **18** is an isometric, right view of the headset **1000** of FIGS. **16** and **17** on the human head **2000** of FIG. **16**. FIG. **19** is an isometric, right view of the headset **1000** of FIGS. **16** through **18**. FIG. **20** is a top view of the headset **1000** of FIGS. **16** through **19**. As shown, the headset **1000** externally comprises:

- a rear cover **1010**;
- selection buttons **1020**;
- rear adjustment dial **1030**;
- notification LEDs **1040**;
- a mouth section adjustment dial **1050**;
- a switchable ear mount **1100**;
- switchable ear mount replacement screws **1110**;
- an inside ear hanger **1150**;
- an ear cushion **1160**;
- a mouth section cover **1200**;
- a mouth seal ring **1210**;
- a Helmholtz vent **1300**;
- a speaker **1400**;
- a right hinge **1500**;
- a left hinge **1600**; and,
- a headset hinge **1700**.

As shown in FIGS. **16** through **20**, the headset **1000** may be worn on the head of a wearer so that the mouth seal ring **1210** is positioned over a user’s **2000** mouth while the ear cushion **1160** and speaker **1400** are positioned against the user’s **2000** ear. In one embodiment, the ear cushion **1160** provides a comfortable seal around the user’s **2000** ear during use. The ear cushion **1160** also dampens ambient noise. The mouth seal ring **1210** suitably is configured to make contact with the user’s face **100** at an angle perpendicular to the mouth opening while sealing comfortably to soft tissue around the mouth while the user is talking. In one embodiment, the seal around the mouth by the mouth piece **1210** is similar to the seal of a scuba diver’s facemask around the eyes of a wearer. As discussed in detail below, the mouthpiece **1210** may move toward or away from the user’s mouth by the adjustment dial **1050**. The headset features a shell for enclosing electrical components. Suitably, the shell is defined by a rear cover **1010** and a mouth section cover.

Suitably, the headset **1000** may be positioned over the ears of a wearer **2000** by ear hangers **1150**. Suitably, ear hangers are reversible so that the ear cushion **1160** and speaker **1400** may be positioned over the left or right ears of a wearer **2000**. As shown, the headset **1000** is over the right ear of a

16

wearer **2000** but the same could be worn over the right ear by (a) swapping out the switchable ear-mount **1100** by removing the screws **1110** and flipping the wear mount **1100** relative to the headset **100**; and (b) flipping the inside ear hanger **1150** relative to the headset **1000**. In a preferred embodiment, the left and right ear hangers **1150** are sized to fit comfortably behind the ear of a wearer **2000**. Suitably, the ear hangers **1150** support the mass of the headset **1000** on the wearer’s **2000** ears as well as applying pressure to the sides of the wearer’s **2000** head. The mouth section of the device **1000** suitably features a Helmholtz vent **1300** defined by slot in the cover where exhaust gasses and sound pressure may exit the device. Suitably, the vent **1300** may contribute to the overall aesthetics of the headset **1000**.

Still referring to FIGS. **16** through **20**, the headset **1000** may be worn on the head of a user **2000**. In a preferred embodiment, the ear cushion **1160** and mouth pieces **1210** are configured for placement so that the device **1000** lies along the mentocervical angle, mentocervical angle length, menton-subnasale length, bitragoin-subnasale arc, or bitragoin-menton arc of a user at a range of nineteen to twenty three degrees. To assist in proper sizing, the rear adjustment dial **1030** may be turned to adjust the width of the device as measured between the two ear hangers **1150**. Suitably, the rear adjustment dial **1030** adjusts the left to right width of the headset **1000** as well as the level of pressure exerted by the headset **1000** on a user’s head **2000**. Suitably, the movement of the headset **1000** relative to the head **2000** may be minimized during use of the headset **1000**. To further assist in proper sizing the depth of the device measured from mouth piece **1210** to the back of the device **1000** may be adjusted by the mouth section adjustment dial **1050**. Suitably, the mouth adjustment dial **1050** adjusts the front to back length of the headset **1000** as well as the distance from and level of pressure exerted by the mouthpiece **1210** on the user’s face **2000**. The adjustment wheel and other dials **1030/1050** may suitably be accessible through the bottom and top of the headset so that it can be gripped on both sides during use. In a preferred embodiment the dial **1030/1050** has deep ridges around the radius to ensure tactical feedback for ease of use while the headset is on the user’s head because the dial **1030/1050** is out of view. Suitably, the adjustment dials **1030/1050** are designed to allow the headset **1000** to be adjusted to fit a range from a first percentile female head to a 99 percentile male head based on available anthropometric data.

In a preferred embodiment, the headset **1000** does not go over the head **2000** like traditional headphones in order to avoid the influence that flexing of the temples during speech may have on the function of the mouth seal **1210** and quality of sound cancellation. Suitably, the dials **1030/1050** may expand and contract the rear and side sections of the headset.

FIG. **18** is a top view of the headset **1000** of FIGS. **16** through **20** in a folded configuration. Suitably, the headset **1000** may be considered collapsible wherein the device **1000** may be folded on itself around the headset hinge **1700**. Suitably, the speaker **1400** is provided at the pivot point to allow for continuous use of the headset in a folded position. Suitably, the headset hinge **1700** allows the headset to fold in half for compact storage. The hinge **1700** further enables the user **2000** to rotate the front of the headset **1000** over their head **2000** and out of the way of their mouth when the mouthpiece **1210** is not in use. Suitably, the hinge **1700** pivots around the speaker **1400** and ear cushion **1160** to ensure that the speaker **1400** and ear cushion **1160** remain in a correct position while the headset **1000** is in a folded configuration. The headset **1000** hinge **1700** is able to stop

incrementally throughout its 180 degree rotational range of motion. Suitably, the stop increments can include, but should not be limited to, 90 degrees for comfortable positioning of the mouthpiece **1210** over the user's **2000** head when the mouthpiece **1210** is not in use as well as at 180 degrees for storage. To further assist in the collapsibility of the headset **1000**, the ear hangers **1150** are provided with hinges **1500**, **1600** so that the hangers **1150** may be folded to minimize headset **1000** size during storage. The left hinge **1500** suitably enables the hangers **1150** to fold backward to minimize size during storage. In a preferred embodiment, the left hinge **1500** range of motion does not enable the left ear hanger **1150** to contact the headset **100** while it is in the folded position and stops in the extended position when the left ear hanger **1150** is in line with the user's head **2000**. The right hinge **1600** also may suitably fold backward relative to the headset **1000**. The right hinge **1600** range of motion does not allow the right ear hanger **1150** to contact the headset **1000** when in its folded position and stops in the extended position whenever the right ear hanger **1150** is in line with the user's head **2000**.

FIG. **22** is an internal right-side view of the headset **1000** of FIGS. **16** through **21** with the mouth cover **1200** and rear cover **1010** removed. FIG. **23A** is an internal backside view of the headset **1000** of FIGS. **16** through **21** with the mouth cover **1200** and rear cover **1010** removed. FIG. **23B** is a see-through internal backside view of the headset **1000** of FIGS. **16** through **21** with the mouth cover **1200** and rear cover **1010** removed. FIG. **24** is an internal back view of the headset **1000** of FIGS. **16** through **21** with the mouth cover **1200** and rear cover **1010** removed. FIG. **25** is an internal front view of the headset **1000** of FIGS. **16** through **21** with the mouth cover **1200** and rear cover **1010** removed. As shown, the device internally comprises:

- the hinge **1700** with a wire through-hole;
- a circuit board **1800**;
- the side adjustment wheel **1050**;
- the rear adjustment wheel **1030**;
- a vibration motor **1800**;
- batteries **1850**;
- weights **1860**;
- small exciters **1870**;
- large exciters **1880**;
- Helmholtz resonator **1890**;
- a microphone **1900**; and,
- acoustic dampeners **1910**.

Referring to FIGS. **22** through **25**, the headset **1000** features a circuit board **1800**. Suitably, the circuit board is curved to mature the curvature of the headset **1000**. In one embodiment, the circuit board **1800** contains all the processing and control operation of the headset. Specifically, the circuit board controls the vibration motor **1250**, the small exciters **1870**, the large exciters **1880**, and the light **1400**, the microphone **1900** and speaker **1400**. Suitably, the control buttons **1210** (FIGS. **16-21**) may be used to control call functionality and settings, including call and phone controls. The LED lights **1400** may suitably be used to notify the user when the headset **1000** is worn, including indications of phone actives such as incoming calls, Bluetooth connection etc. The vibration motor **1250** may suitably be used to provide sensory feedback for varying phone functions including but not limited to incoming calls or call waiting. The small exciters **1870** may suitably be used to produce white and pink noise to aid in active noise canceling or masking of a user's voice and should be included in ANC means. The large exciters **1880** are intended for active noise cancellation of the user's voice including the cancellation of

low frequency sound pressure. The microphone **1900** may be used to pick-up the voice during headset **1000** use. As shown, the microphone **1900** may be positioned at the front of the mouth and centered to incoming sounds from the mouth. As shown, a wire harness **1920** may be used to route through the interior of the phone for energy and data transfer. In a preferred embodiment, the electronic components may be powered by batteries **1850**. In one embodiment, the batteries **1850** are sized to ensure extended use of the headset without the need for charging or for power cables. In one embodiment the batteries **1850** are positioned at the back of the headset **1000** so that the weight of the batteries **1850** can assist in balancing the headset **1000**. Other balancing weights **1860** may be positioned along the side of the headset **1000** for balanced weight distribution. Suitably, the hinge **1700** may suitably feature a hole there through so that wires may be provided between the speaker **1400** and circuit board **1800** without affecting the collapsibility of the headset **1000**. Also, the hole through the hinge allows the electrical components to be connected to the batteries and circuit board **1800** while the headset **1000** is folded. Finally, the headset **1000** features a Helmholtz resonator **1890**. Suitably, the Helmholtz resonator **1890** is designed to dampen sound pressure emitted by the users while talking. In a preferred embodiment, exhaled as is contained and passed through the tuned Helmholtz resonator **1890** for treatment before being exhausted out of the phone via the vents **1300**.

FIG. **26** is a cross-section of a mouth portion of the headset **1000** of FIGS. **16** through **23**. Suitably, the mouth portion of the headset **1000** features acoustic dampeners **1910**. As shown, the dampeners **1910** are defined by triangles or pyramids of sound absorbing material. Suitably the dampeners **1910** are positioned in front of the user's mouth inside the sound collection chamber **1210** of the headset **1000**. The dampeners **1910** are suitably part of the passive sound cancellation system to absorb mainly high frequency sound pressure. Suitably the chamber **1210** may be removable for sanitation purposes.

Although the method and apparatus is described above in terms of various exemplary embodiments and implementations, it should be understood that the various features, aspects and functionality described in one or more of the individual embodiments are not limited in their applicability to the particular embodiment with which they are described, but instead might be applied, alone or in various combinations, to one or more of the other embodiments of the disclosed method and apparatus, whether or not such embodiments are described and whether or not such features are presented as being a part of a described embodiment. Thus the breadth and scope of the claimed invention should not be limited by any of the above-described embodiments.

Terms and phrases used in this document, and variations thereof, unless otherwise expressly stated, should be construed as open-ended as opposed to limiting. As examples of the foregoing: the term "including" should be read as meaning "including, without limitation" or the like, the term "example" is used to provide exemplary instances of the item in discussion, not an exhaustive or limiting list thereof, the terms "a" or "an" should be read as meaning "at least one," "one or more," or the like, and adjectives such as "conventional," "traditional," "normal," "standard," "known" and terms of similar meaning should not be construed as limiting the item described to a given time period or to an item available as of a given time, but instead should be read to encompass conventional, traditional, normal, or standard technologies that might be available or known now or at any time in the future. Likewise, where this document refers to

technologies that would be apparent or known to one of ordinary skill in the art, such technologies encompass those apparent or known to the skilled artisan now or at any time in the future.

The presence of broadening words and phrases such as “one or more,” “at least,” “but not limited to” or other like phrases in some instances shall not be read to mean that the narrower case is intended or required in instances where such broadening phrases might be absent. The use of the term “assembly” does not imply that the components or functionality described or claimed as part of the module are all configured in a common package. Indeed, any or all of the various components of a module, whether control logic or other components, might be combined in a single package or separately maintained and might further be distributed across multiple locations.

Additionally, the various embodiments set forth herein are described in terms of exemplary block diagrams, flow charts and other illustrations. As will become apparent to one of ordinary skill in the art after reading this document, the illustrated embodiments and their various alternatives might be implemented without confinement to the illustrated examples. For example, block diagrams and their accompanying description should not be construed as mandating a particular architecture or configuration.

All original claims submitted with this specification are incorporated by reference in their entirety as if fully set forth herein.

PAPER “SEQUENCE LISTING”

Not applicable.

We claim:

1. A telephone headset comprising: a support arm that defines a telephone component housing; at least a mouthpiece disposed at a first end of the support arm, said mouthpiece positioned adjacent to a mouth of a user, said mouth piece featuring a plurality of active exciters, acoustic dampeners, a Helmholtz resonator, and a microphone for receiving sounds to be telecommunicated, wherein said microphone for receiving sounds is directed toward said mouth of the user, and wherein said plurality of active exciters are configured to actively cancel noise from said mouth; an ear chamber disposed at a second end of the support arm with an ear opening for engaging the ear of a user; a speaker, disposed within the component housing and configured to communicate sound into the ear chamber; means for receiving and transmitting a telephonic or other electronic communication disposed within the component housing, said means electronically coupled to said speaker, said microphone, and said plurality of active exciters.

2. The telephone headset of claim 1 wherein the support arm features a side adjustment wheel.

3. The telephone headset of claim 2 wherein the support arm features a rear adjustment wheel.

4. The headset of claim 3 wherein the support arm is configured so that the ear chamber engages the ear of a user while the mouth piece simultaneously resides in front of the mouth of a user, and wherein the side adjustment wheel is configured to move the mouth piece relative to the user’s mouth.

5. The headset of claim 3 further comprising ear hangers where said rear adjustment wheel is configured to control the distance between said hear hangers.

6. The headset of claim 5 wherein the support arm is supported between the ear piece and mouth piece so that said arm is positioned along the jaw of a user when worn at a

metocervical angle of about nineteen degrees for female users and about twenty three degrees for male users.

7. The headset of claim 6 wherein the support arm is supported between the ear piece and mouth piece so that said arm is positioned along the jaw of a user when worn at a metocervical angle in a range of fifteen and twenty five degrees.

8. The headset of claim 5 wherein a circuit board is disposed within the support arm, wherein the circuit board is curved along a curvature of the support arm and further defined by

a female jack, wherein the female jack receives a lever operated quick disconnect male jack,

a mechanical switch defined by a physical switch, whereby the physical switch moves when a registered jack phone cord is inserted into the female jack, and a mechanical physical analog to digital and then digital to analog sensing switch.

9. The headset of claim 8, wherein the circuit board: determines voltage levels used for a speaker and the bias voltage in a microphone;

gathers the information from a sensor;

determines which signal is present in at least one wire; and

activates a switch to create a route for audio and voltage signals, whereby the headset may be employed with different land line wiring configurations.

10. The telephone headset of claim 1 where the support arm features a headset hinge so that the mouthpiece may fold over said support arm.

11. A method of privately communicating comprising the steps of: obtaining a telephone headset comprising—a support arm, a mouthpiece disposed at a first end of the support arm, said mouth piece featuring a plurality of active exciters, acoustic dampeners, a Helmholtz resonator, and a microphone for receiving sounds to be telecommunicated, wherein said microphone for receiving sounds is directed toward said mouth of the user, and wherein said plurality of active exciters are configured to actively cancel noise from said mouth, an ear chamber disposed at a second end of the support arm with an ear opening for engaging the ear of a user; simultaneously positioning the mouth opening in front of the mouth of a user and engaging the ear opening with an ear respectively; and, communicating via the mouth so that air is received over the mouthpiece and sound energy is destructed via antiphase noise from the plurality of active exciters.

12. The method of claim 11 wherein the arm is supported between the ear piece and mouth piece so that said arm is positioned along a jaw at a metocervical angle in a range of fifteen and twenty five degrees after the step of simultaneously engaging the mouth opening and ear opening with a mouth and ear respectively.

13. The method of claim 12 wherein the metocervical angle is about nineteen degrees for female users.

14. The method of claim 13 wherein the metocervical angle is about twenty three degrees for male users.

15. The method of claim 13 wherein the support arm features a rear adjustment wheel.

16. The method of claim 15 where the support arm features a headset hinge so that the mouthpiece may fold over said support arm.

17. The method of claim 16 wherein the support arm is configured so that the ear chamber engages the ear of a user while the mouth piece simultaneously resides in front of the

mouth of a user, and wherein the side adjustment wheel is configured to move the mouth piece relative to the user's mouth.

18. The method of claim 17 further comprising two ear hangers where said rear adjustment wheel is configured to control the distance between said ear hangers. 5

19. The method of claim 18 further comprising the step of adjusting the rear adjustment wheel so that the hangers move relative to one another.

20. The method of claim 12 wherein the support arm features a side adjustment wheel. 10

* * * * *